

GENERAL MICROBIOLOGY

MBIO 140

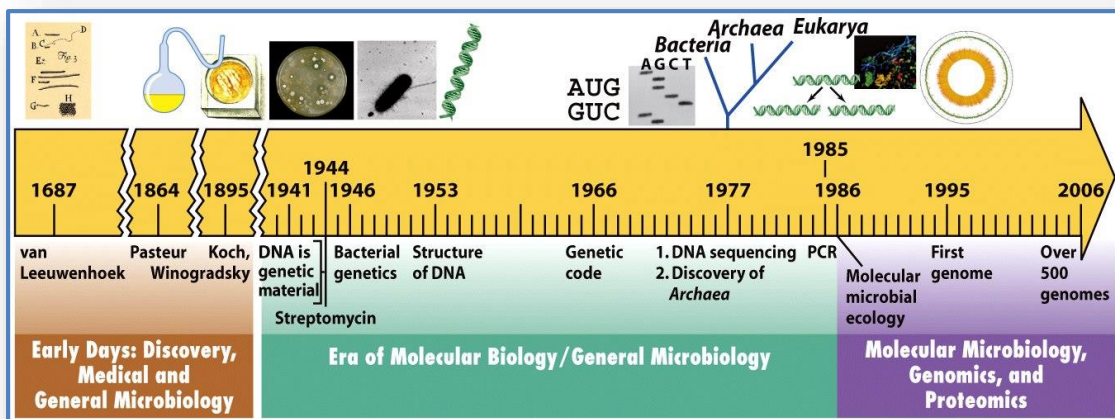
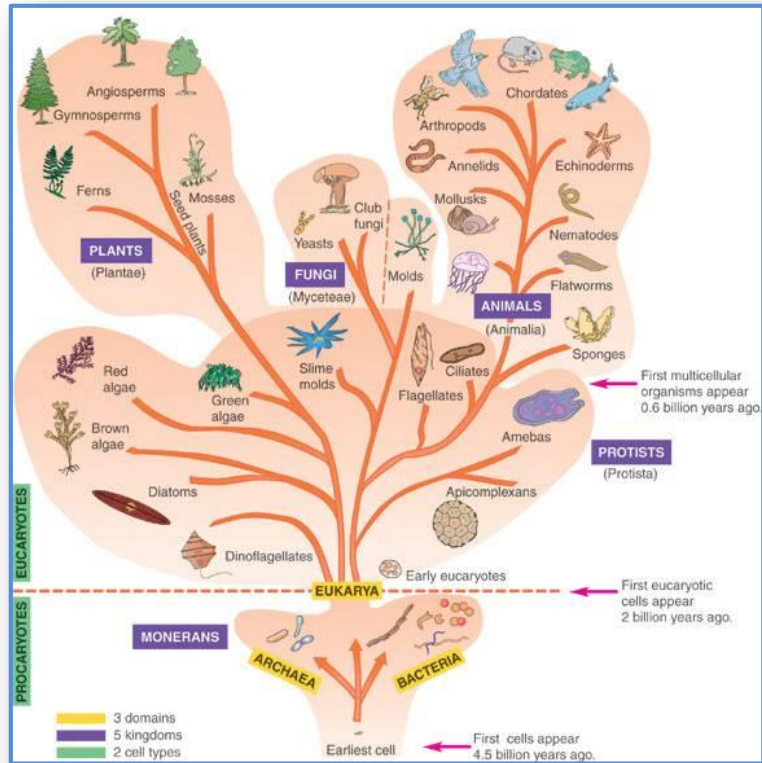

“...THE ROLE OF THE INFINITELY SMALL IN NATURE IS INFINITELY LARGE”.... Louis Pasteur

Welcome to microbiology—the study of microorganisms.

Microorganisms are single-celled microscopic organisms and viruses, which are microscopic but not cellular.

What is microbiology all about?

- Microbiology is **about cells and how they work**, especially the **bacteria**, a large group of cells of enormous basic and practical importance (**Figure 1.1**).

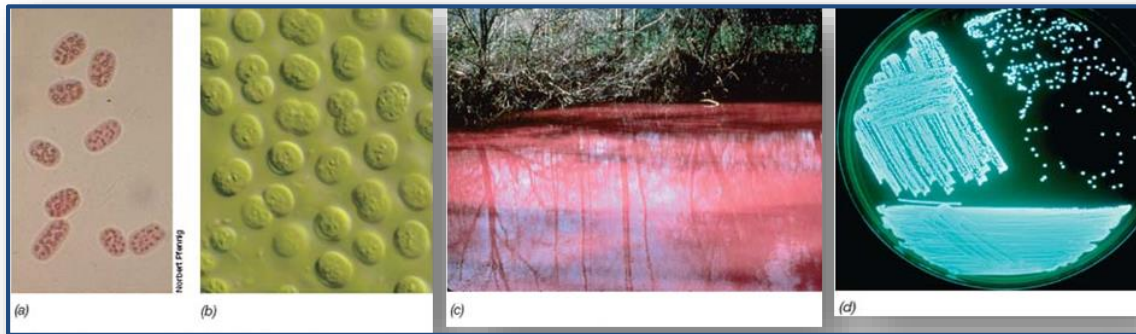

Figure 1.1 Microorganisms. (a, b) A single microbial cell can have an independent existence. Shown are photomicrographs of phototrophic (photosynthetic) microorganisms called (a) purple bacteria and (b) cyanobacteria and (d) bioluminescent (light-emitting) cells of the bacterium *Photobacterium leiognathi* grown in laboratory culture. One milliliter of water from the lake (c) or one colony from the plate (d) contains more than 1 billion (10^9) individual cells.

- Microbiology is about **diversity** and **evolution**, about how different kinds of microorganisms arose and why.
- It is about **what microorganisms do** in the **world** at large, in **soils** and **waters**, in the **human body**, and in **animals** and **plants**.
- One way or another, microorganisms **affect all other life forms** on Earth, and thus we may think of **microbiology** as the **foundation of the biological sciences**.
- **Microorganisms differ from the cells of macroorganisms.** The cells of **macroorganisms** such as plants and animals are **unable to live alone** in nature and exist only as parts of **multicellular structures**, such as the organ systems of animals or the leaves of leafy plants.

- By contrast, **most microorganisms** can carry out their life processes of growth, energy generation, and reproduction **independently** of other cells.

1. INTRODUCTION TO MICROBIOLOGY

1.1 Microbiology

The science of microbiology revolves around two themes:

(1) Understanding basic life processes, and

- As a basic biological science, microbiology uses and develops tools for probing the fundamental processes of life .
- Scientists have been able to gain a sophisticated understanding of the chemical and physical basis of life from studies of microorganisms because microbial cells share many characteristics with cells of multicellular organisms; indeed, all cells have much in common .
- Moreover, microbial cells can grow to extremely high densities in laboratory culture, making them readily amenable to biochemical and genetic study .
- These features make microorganisms excellent models for understanding cellular processes in multicellular organisms, including humans

(2) Applying our understanding of microbiology for the benefit of humankind.

As an applied biological science, microbiology deals with many important practical problems in medicine, agriculture, and industry For example:

- Most animal and plant diseases are caused by microorganisms .
- Microorganisms play major roles as agents of soil fertility and in supporting domestic animal production .

- Many large-scale industrial processes, such as the production of antibiotics and human proteins, rely heavily on microorganisms. Thus both the detrimental and the beneficial aspects of microorganisms affect the everyday lives of humans.

The Importance of Microorganisms

- In this book we will see that **microorganisms play central roles in both human activities and the web of life on Earth.**
- Although **microorganisms** are **the smallest forms** of life, collectively they **constitute the largest mass** of living material on Earth and carry out many chemical processes necessary for other organisms.
- In the **absence of microorganisms, other life forms would never have arisen** and could not now be sustained. Indeed, the **very oxygen** we breathe is the result of past **microbial** activity (Figure 1.1*b*).
- Moreover, we will see how **humans, plants, and animals** are intimately **tied to microbial activities** for the recycling of **key nutrients** and for degrading organic matter.
- No other life forms are as important as microorganisms for the support and maintenance of life on Earth.
- Microorganisms existed **on Earth for billions of years before plants and animals** appeared, and we will see in later chapters that the **diversity** of microbial life **far exceeds** that of the plants and animals.
- This huge **diversity accounts** for some of the **spectacular properties** of microorganisms. For example, we will see how **microorganisms can live in places unsuitable for other organisms** and how the diverse physiological capacities of microorganisms rank them as Earth's premier chemists.

1.2. PATHWAYS OF DISCOVERY IN MICROBIOLOGY

Like any science, microbiology owes much to its past. Although able to claim early roots, the science of microbiology didn't really develop until the **nineteenth century**. Since that time, the field has exploded and spawned several new but related fields. We retrace these pathways of discovery now.

The Historical Roots of Microbiology: Hooke, van Leeuwenhoek, and Cohn

- Although the existence of **creatures too small to be seen with** the naked eye had long been suspected, **their discovery** was linked to the **invention** of the **microscope**.
- **Robert Hooke** (1635–1703), an English mathematician and natural historian, was also an excellent microscopist. In his famous book *Micrographia* (1665), the first book devoted to microscopic observations, **Hooke** illustrated, among many other things, the fruiting structures of **molds** (**Figure 1.9**). This was **the first known description of microorganisms**.
- The first person to see **bacteria** was the Dutch draper and amateur microscope builder **Antoni van Leeuwenhoek** (1632–1723).

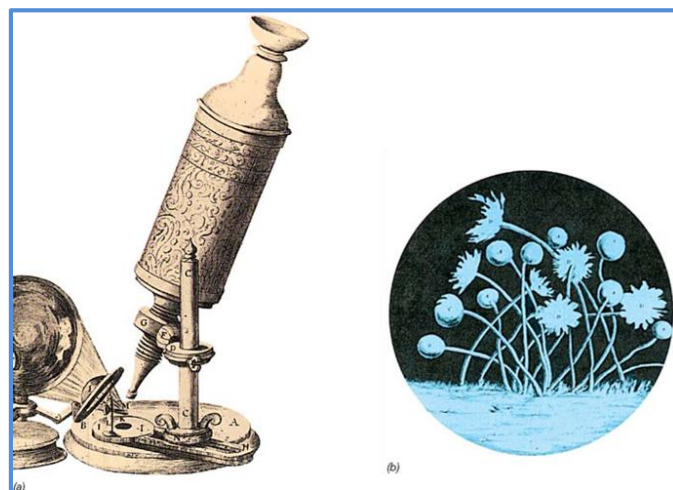

Figure 1.9: Robert Hooke and early microscopy. (a) A drawing of the microscope used by Robert Hooke in 1664. This drawing, published in *Micrographia* in 1655, is the first description of a microorganism. The organism is a bluish-colored mold growing on the surface of leather. The round structures (sporangia) contain spores of the mold.

- In **1684**, van **Leeuwenhoek**, who was aware of the work of Hooke, used extremely simple microscopes of his own construction (**Figure 1.10**) to examine the microbial content of a variety of natural substances
- **Van Leeuwenhoek's** microscopes were **crude** by today's standards, but by careful manipulation and focusing he was able to see **bacteria**, microorganisms considerably smaller than molds. He **discovered bacteria** in **1676** while studying **pepper-water infusions**.
- He reported his observations in a series of letters to the prestigious Royal Society of London, which published them in **1684** in English translation. Drawings of some of van Leeuwenhoek's "**wee animalcules**," as he referred to them, are shown in **Figure 1.10b**.
- As years went by, van Leeuwenhoek's observations were **confirmed by others**, but progress in understanding the nature and importance of these tiny organisms remained slow for nearly the next **150 years**.
- Only in the nineteenth century did **improved microscopes** become widely distributed, and about this time the extent and nature of microbial life forms became more apparent.
- **In the mid- to late nineteenth century** major advances were made in the new science of microbiology, primarily because of the attention that was given to two major questions that pervaded biology and medicine at the time: **(1) does spontaneous generation occur** and **(2) what is the nature of infectious disease**.
- **Answers** to these penetrating **questions** emerged from the work of **two giants** in the fledgling field of microbiology: the French chemist **Louis Pasteur** and the German physician **Robert Koch**. But before we explore their work, let us briefly consider the groundbreaking work of a German **botanist, Ferdinand Cohn**, a contemporary of **Pasteur** and **Koch** and the **founder** of the field we now call *bacteriology*

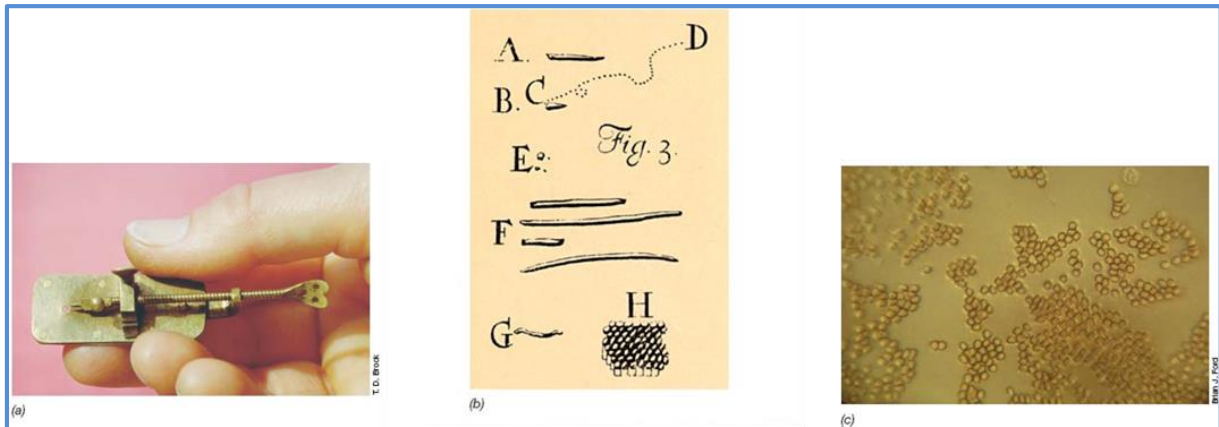

Figure 1.10 The van Leeuwenhoek microscope. (a) A replica of van Leeuwenhoek's microscope. The lens is mounted in the brass plate adjacent to the tip of the adjustable focusing screw. (b) Antoni van Leeuwenhoek's drawings of bacteria, published in 1684. Even from these relatively crude drawings we can recognize several shapes of common bacteria: A, C, F, and G, rod shaped; E, spherical or coccus-shaped; H, cocci packets. (c) Photomicrograph of a human blood smear taken through a van Leeuwenhoek microscope. Red blood cells are clearly apparent. A single red blood cell is about 6 μm in diameter.

Ferdinand Cohn and the Science of Bacteriology:

- Ferdinand Cohn (1828–1898) was born in Poland. He was trained as a botanist and became an excellent microscopist.
- His interests in microscopy naturally led him to the study of unicellular plants—the **algae**—and later to **photosynthetic bacteria**.
- Cohn believed that all **bacteria**, even those lacking photosynthetic pigments, were members of the **plant kingdom**, and his microscopic studies gradually drifted away from plants and algae to bacteria, including the large sulfur bacterium *Beggiatoa* (**Figure 1.11**).
- **Cohn** was particularly interested in heat resistance in bacteria, which led him to discover the important group of bacteria that form **endospores**.

- We now know that bacterial **endospores** are **extremely heat resistant**. Cohn described the life cycle of the endospore-forming bacterium *Bacillus* (**vegetative cell** → **endospore** → **vegetative cell**) and discovered that **vegetative** cells of *Bacillus* but not their endospores were killed by boiling.
- Indeed, Cohn's discovery of endospores helped explain why his contemporaries, such as the Irish scientist **John Tyndall**, had found **boiling** to be an **unreliable** means of preventing fluid infusions from supporting microbial growth.
- Cohn laid the ground work for a system of **bacterial classification**, including an early attempt to define the nature of a **bacterial species**, an issue still unresolved today

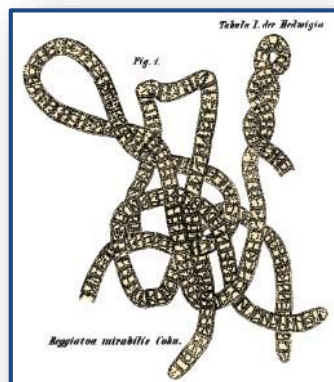

Figure 1.11. Drawing by Ferdinand Cohn made in 1866 of the large filamentous sulfur-oxidizing bacterium *Beggiatoa mirabilis*.

MiniReview

Robert Hooke was the first to describe microorganisms, and Antoni van Leeuwenhoek was the first to describe bacteria. Ferdinand Cohn founded the field of bacteriology and discovered bacterial endospores

1. What prevented the science of microbiology from developing before the era of van Leeuwenhoek?
2. What major discovery emerged from Cohn's study of heat resistance in microorganisms?

Pasteur and the Defeat of Spontaneous Generation

- The **mid- to late nineteenth century** saw the science of microbiology **blossom**.
- The concept of **spontaneous generation** was **crushed** and the science of **pure culture microbiology** emerged.
- Several scientific giants emerged in this era, and the first was the Frenchman **Louis Pasteur (1822–1895)**, a contemporary of **Cohn**. Pasteur was trained as a chemist

Fermentations

- At the **invitation** of a local **industrialist** who was having problems making **alcohol** by the **fermentation of beets**, **Pasteur began a detailed study of the mechanism of the alcoholic fermentation**, at that time thought to be a **strictly chemical process**.
- The **yeast** cells in the **fermenting** broth were thought to be a **complex chemical substance and a result, rather than a catalyst, of the fermentation**.
- Microscopic observations and other simple but rigorous experiments convinced Pasteur that the alcoholic fermentation was catalyzed by living yeast cells. Indeed, in Pasteur's own words: “. . . **fermentation is associated with the life and structural integrity of the cells and not with their death and decay.**”
- From this foundation, **Pasteur** began a series of classic experiments on **spontaneous generation**, experiments that are forever linked to his name and to the **science of microbiology**.

Spontaneous Generation:

- The concept of **spontaneous generation** had existed since **biblical times**.
- The **basic idea** of **spontaneous generation** can easily be understood. For example, if food is allowed to stand for some time, it **putrefies**.
- When the putrefied material is examined microscopically, it is found to be **teeming** with **bacteria** and perhaps even higher organisms such as **maggots and worms**.

- **Where do these organisms that are not apparent in the fresh food come from?** Some people said they **developed from seeds or germs that entered the food from air**. Others said **they arose spontaneously from nonliving materials**, that is, **spontaneous generation**. **Who was right?**
- Keen insight was necessary to **solve this controversy**, and this was exactly the kind of problem that appealed to Louis Pasteur.
- Pasteur was a powerful **opponent** of **spontaneous generation**. Following his discoveries about **fermentation**.
- Pasteur showed that microorganisms closely resembling those observed in **putrefying materials** could be found in **air**.
- Pasteur concluded that the **organisms** found in putrefying materials **originated** from **microorganisms** present in the air and on the surfaces of the **containers** that **held the materials**.
- He **postulated** that cells are constantly being **deposited on all objects** and that they **grow** when **conditions** are **favorable**. Furthermore, Pasteur reasoned that if **food** were **treated** in such a way as to **destroy all living organisms** contaminating it, that is, if it were rendered **sterile** and then **protected** from further **contamination**, it should not putrefy.
- Pasteur used **heat to eliminate contaminants**. Other workers had shown that when a nutrient solution was sealed in a glass flask and heated to boiling for several minutes, it did not support microbial growth (of course, only if endospores were not present; see discussion of Cohn). **Killing all the bacteria** or other microorganisms in or on objects is a process we now **call sterilization**.
- **Proponents** of spontaneous generation **criticized** such experiments by **declaring** that “**fresh air**” was necessary for the phenomenon to occur. **Boiling**, so they claimed, in

some way **affected the air** in the **sealed flask** so that it could **no longer support spontaneous generation**.

- In 1864 Pasteur **countered** this **objection** simply and brilliantly by constructing a **swan-necked flask**, now called a *Pasteur flask* (**Figure 1.13**).
- In such a flask **nutrient solutions** could be **heated to boiling** and sterilized. However, after the flask was **cooled**, air was allowed to reenter, but **bends in the neck** (the “swan neck” design) **prevented particulate matter** (containing microorganisms) from **entering** the main body of the flask and causing **putrefaction**.

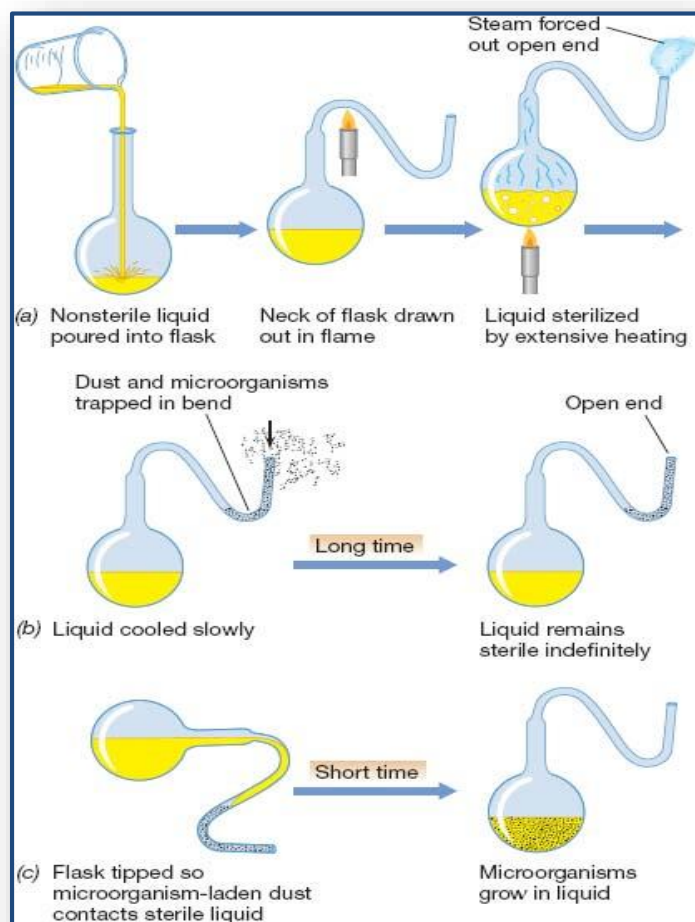

Figure 1.13. The defeat of spontaneous generation: Pasteur’s experiment with the swan-necked flask. (a) Sterilizing the contents of the flask. (b) If the flask remained upright, no microbial growth occurred. (c) If microorganisms trapped in the neck reached the sterile liquid, microbial growth ensued

- Broth **sterilized** in a Pasteur flask **did not putrefy**, and **microorganisms never appeared** in the flask as long as the **neck did not** contact the **sterile liquid**.
- If, however, the **flask** was **tipped** to allow the sterile liquid to **contact** the **contaminated** neck of the flask (Figure 1.13c), **putrefaction occurred** and the liquid soon **teemed** with **microorganisms**.
- This simple experiment effectively settled the controversy surrounding spontaneous generation, and the science of microbiology was able **to move ahead on firm footing**.
Incidentally,
- Pasteur's work also led to the development of **effective sterilization procedures** that were eventually refined and carried over into both basic and **applied microbiological research**.
- Food science also owes a debt to Pasteur, as his principles are applied today in the canning and **preservation of milk and other foods** (pasteurization).

Other Accomplishments of Louis Pasteur:

- Pasteur went on to many other triumphs in **microbiology** and **medicine** beyond his seminal work on spontaneous generation.
- Some highlights include his development of **vaccines** for the diseases **anthrax**, fowl **cholera**, and **rabies** during a very scientifically productive period in his life from 1880 to 1890.
- Pasteur's work on **rabies** was his most famous success, culminating in July of **1885** with the first administration of a **rabies vaccine to a human**, a young French boy named Joseph Meister who had been bitten by a rabid dog. In those days, a bite from a rabid animal was akin to a death sentence.

- News of the success of Meister’s vaccination, and that of a young shepherd boy, Jean Baptiste Jupille (**Figure 1.14a**), administered shortly thereafter, spread quickly, and within a year nearly **2500 people** had come to Paris to be treated with Pasteur’s rabies vaccine.

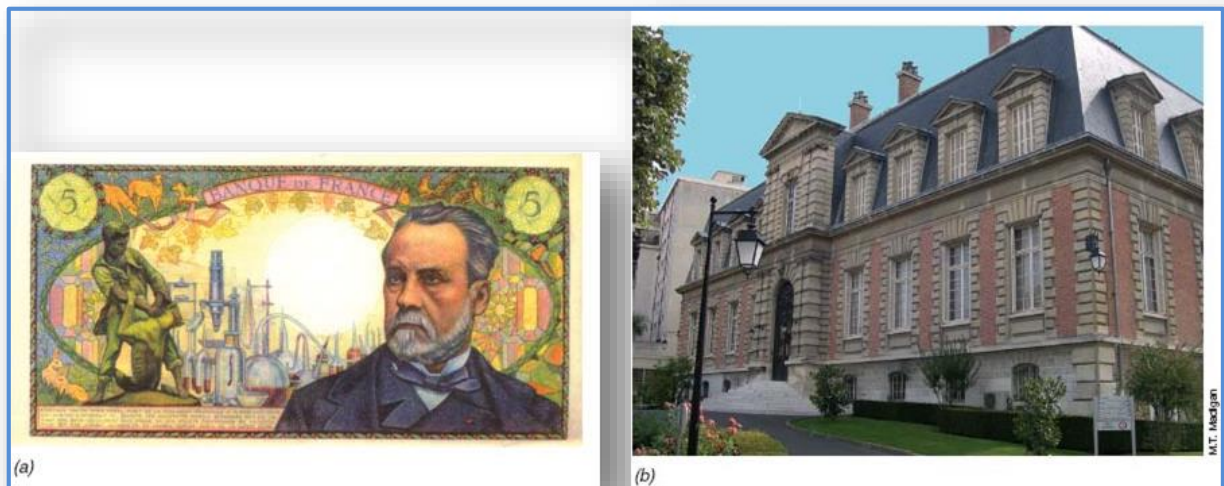

Figure 1.14. Louis Pasteur and symbols of his contributions to microbiology. (a) A French 5-franc note.

MiniReview

Louis Pasteur is best remembered for his ingenious experiments showing that living organisms were not spontaneously generated from nonliving matter. Pasteur’s work in this area led to many of the basic techniques central to the science of microbiology, including the concept and practice of sterilization

1. **Define the term sterile.**
2. **How did Pasteur’s swan-neck flask experiment show that the concept of spontaneous generation was invalid?**

Robert Koch (1843–1910), Infectious Disease, and the Rise of Pure Culture

Microbiology:

- **Proof** that **microorganisms** could **cause disease** provided perhaps the **greatest impetus** for the **development** of the science of **microbiology**.
- Even in the **sixteenth** century it was thought that something that induced a disease could be transmitted from a diseased person to a healthy person.
- After the discovery of microorganisms, it was widely believed that **they were responsible**, but **definitive proof was lacking**.

The Germ Theory of Disease and Koch's Postulates:

- In his early work Koch studied **anthrax**, a **disease** of **cattle** and occasionally of **humans**.
- Anthrax is caused by an endospore-forming bacterium called *Bacillus anthracis*.
- By careful **microscopy** and by using special **stains**, Koch established that the **bacteria** were always **present** in the **blood** of an **animal** that was succumbing to the **disease**.
- However, Koch reasoned that mere **association of the bacterium** with the **disease** was **not proof** that it actually caused the disease. Instead, the bacterium might be **a result of the disease**. How could cause and effect be linked? With anthrax Koch sensed an opportunity to study cause and effect experimentally, and his results formed the standard by which infectious diseases have been studied ever since.
- Koch used mice as experimental animals. Using all of the proper controls, Koch demonstrated that when a **small amount of blood** from a **diseased mouse** was **injected** into a **healthy** mouse, the latter quickly **developed anthrax**.
- He took blood from this **second** animal, injected it into **another**, and again obtained the characteristic disease symptoms.
- However, Koch carried this experiment a critically important step further. He discovered that the anthrax bacteria could be **grown in nutrient fluids outside the animal body** and

that even after many transfers in laboratory **culture**, the bacteria still caused the disease when inoculated into a healthy animal.

- On the basis of these and related experiments carried out in his seminal work on the causative agent of tuberculosis, Koch formulated a set of rigorous criteria, now known as **Koch's postulates**, for definitively linking a specific microorganism to a specific disease:
 1. **The disease-causing organism must always be present in animals suffering from the disease and should not be present in healthy animals.**
 2. **The organism must be cultivated in a pure culture away from the animal body**
 3. **The isolated organism must cause the disease when inoculated into a healthy susceptible animal**
 4. **The organism must be reisolated from these experimental animals and cultured again in the laboratory, after which it should still be the same as the original organism**
- Koch's postulates are summarized in **Figure 1.15**. Koch's postulates were a monumental step forward in the study of infectious diseases.
- The postulates not only offered a means for linking the cause and effect of an infectious disease, but also stressed the importance of laboratory culture of the putative infectious agent. With these postulates as a guide, Koch, his students, and those that followed them discovered the causative agents of most of the important infectious diseases of humans and other animals.
- These discoveries led to the development of successful treatments for the prevention and cure of many of these diseases, thereby greatly improving the scientific basis of clinical medicine and human health and welfare (Figure 1.8)

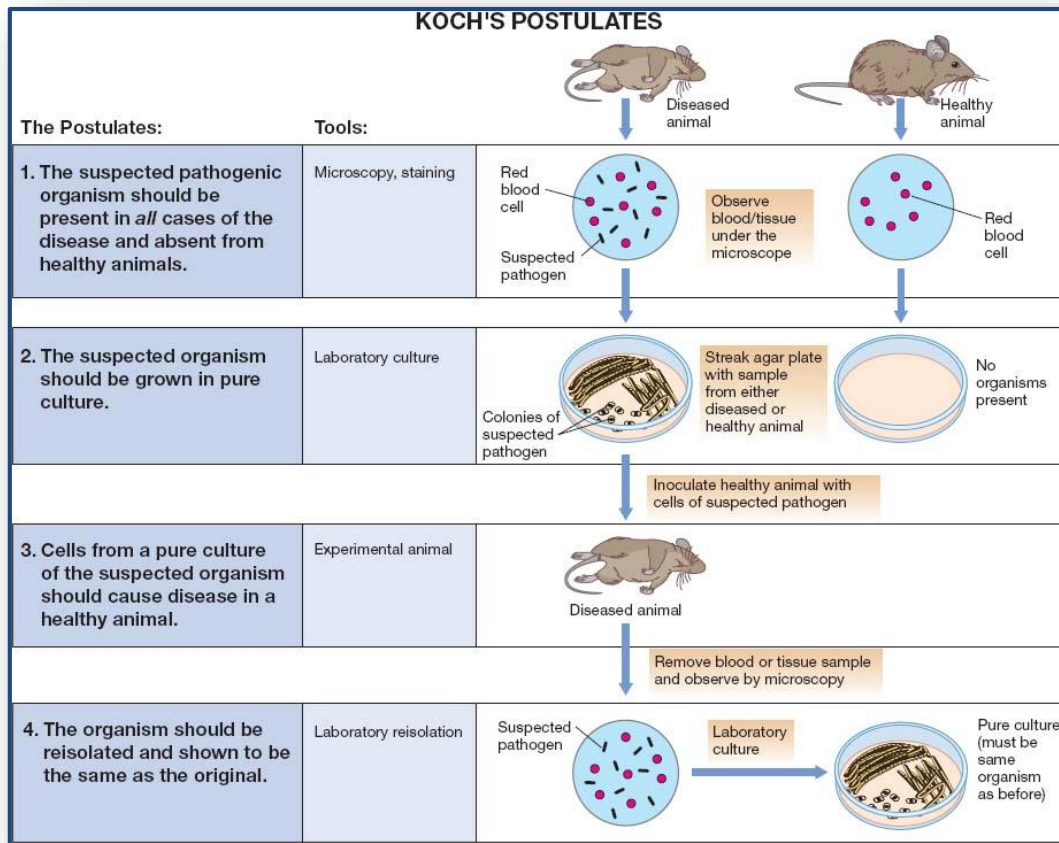

Figure 1.15 Koch's postulates for proving that a specific microorganism causes a specific disease. Note that following isolation of a pure culture of the suspected pathogen, a laboratory culture of the organism should both initiate the disease and be recovered from the diseased animal. Establishing the correct conditions for growing the pathogen is essential, otherwise it will be missed.

The Modern Era of Microbiology:

In the middle to latter part of the twentieth century, basic and applied microbiology worked hand in hand to usher in the current era of molecular microbiology. **Figure 1.16** depicts some of the landmarks in microbiology in the past 65 years.

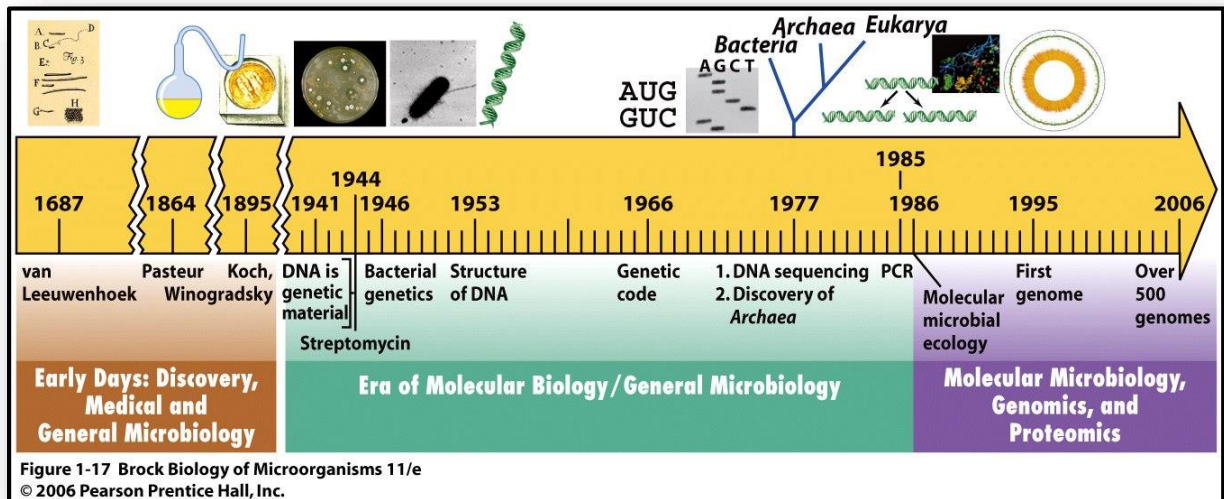

Figure 1.16: Some of the landmarks in microbiology in the past 65 years.

Some subdisciplines of applied microbiology include:

Medical microbiology, immunology, agricultural microbiology, industrial microbiology, aquatic microbiology, marine microbiology, and microbial ecology

Some subdisciplines of basic microbiology include:

Microbial systematics, microbial physiology, cytology, microbial biochemistry, bacterial genetics, and molecular biology

1.3. General Characteristics of Microorganisms

- **Prokaryotes:** No nucleus and organelles
- **Eukaryotes:** Membrane bound nucleus and organelles
- **Acellular agents (Viruses):** Genomes contain either DNA or RNA; newer agent is proteinaceous

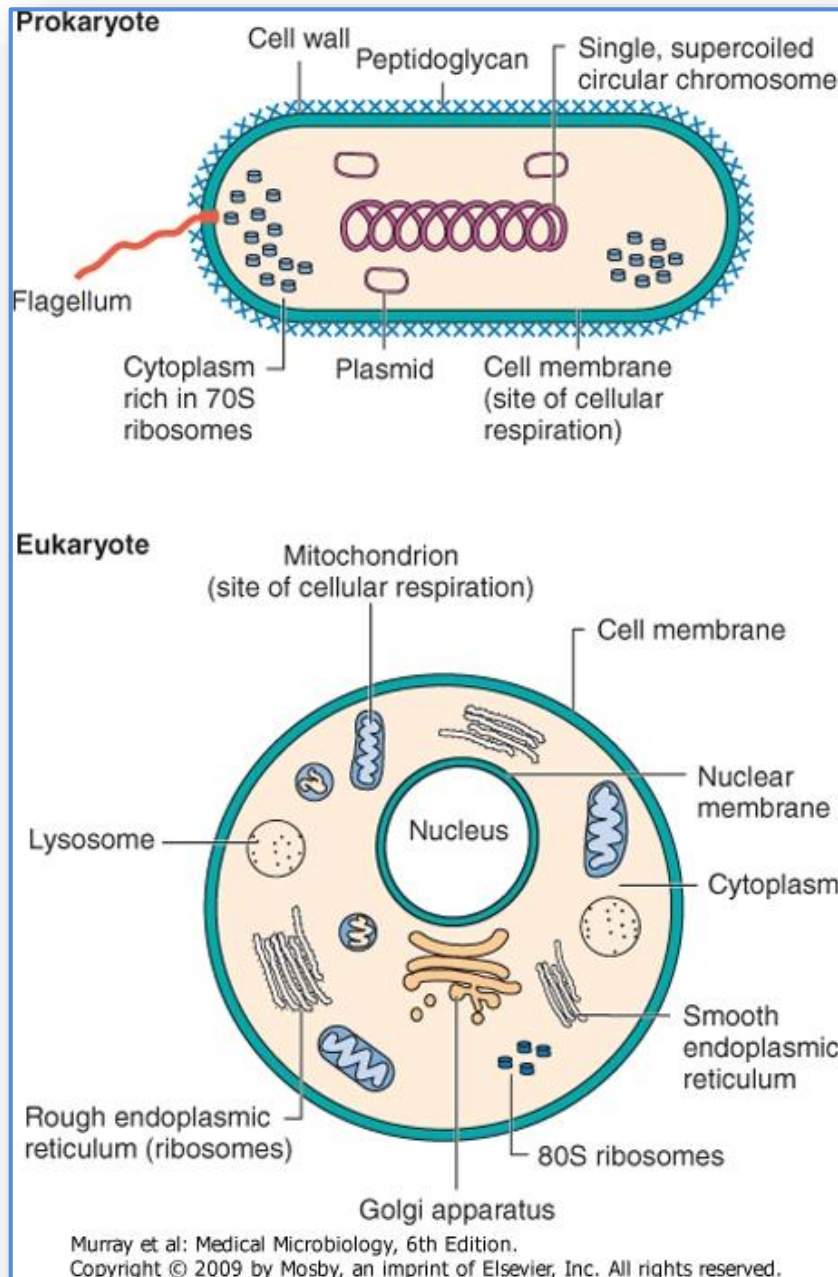

Prokaryotic and Eukaryotic cell

Size of microorganisms

Microorganisms vary in size ranging from 10 **nm** (nanometers) to 100 **µm** (micrometers):

- Viruses in **nm** = 10^{-9} **m** (meter)
- Bacteria in **µm** = 10^{-6} **m**
- Helminths in **mm** = 10^{-3} **m**

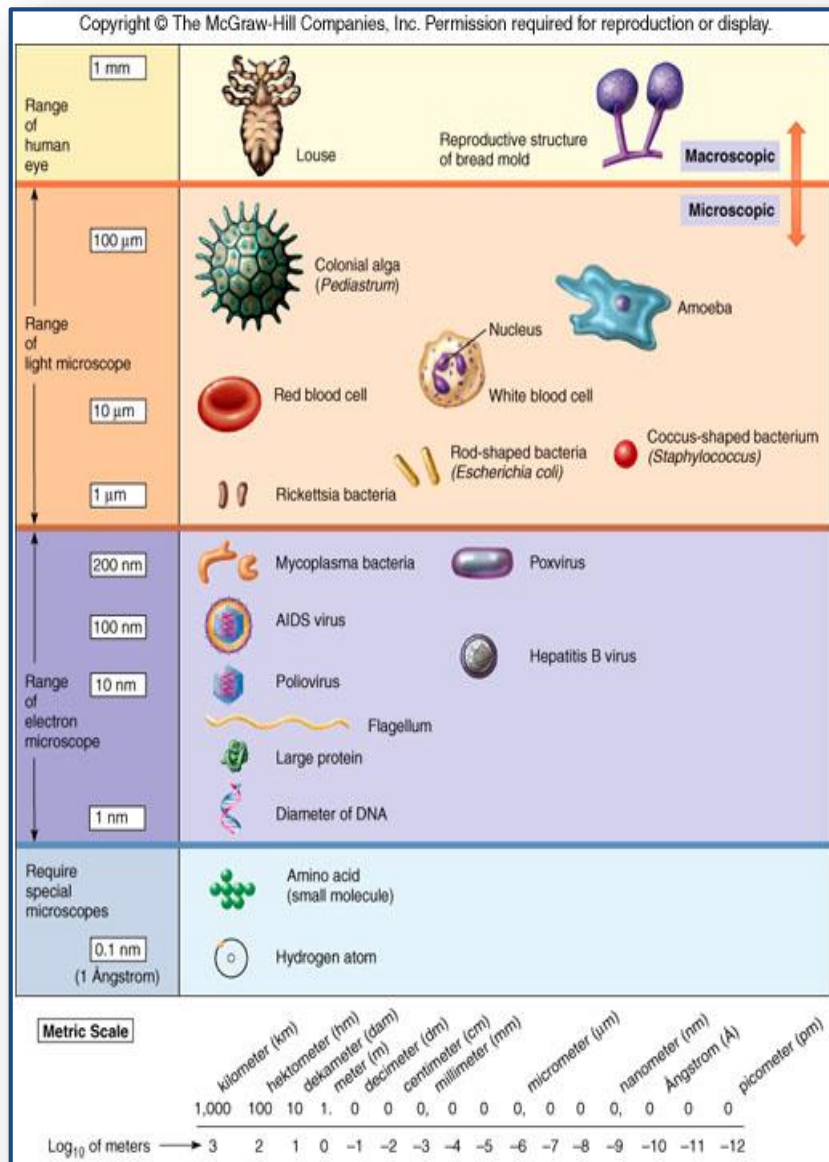

Size of microorganisms

Classification of microorganisms

System for organizing, classifying, and naming living microorganisms Primary concerns of taxonomy are **classification**, **nomenclature**, and **identification**.

Classification:

The **Domain** system was developed by **Dr. Woese**. The **basis** of the Domain system is the **rRNA sequence** information.

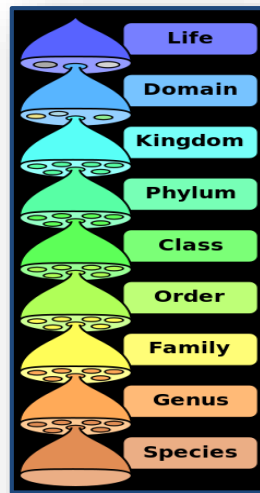

Classification of microorganisms

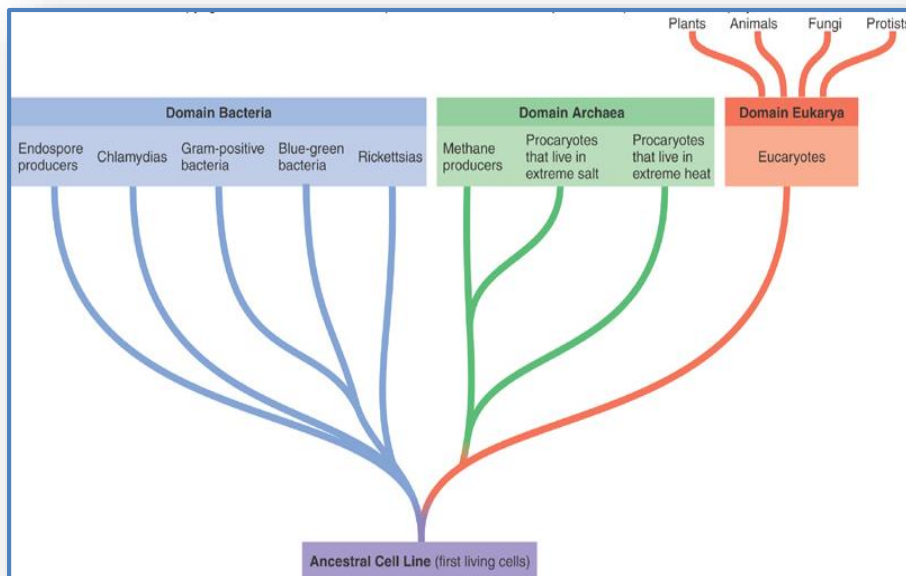

Nomenclature:

- Learn **Binomial** (scientific) nomenclature
- **Genus** –*Saccharomyces*, always **capitalized**
- **species** - *cerevisiae*, **lowercase**
- Both **italicized** or **underlined**: *Saccharomyces cerevisiae* or Saccharomyces cerevisiae

Identification:

The process of microbial identification and placing them in a taxonomic scheme includes:

1. Microscopic morphology and colony appearance
2. Physiological/biochemical characteristics
3. Chemical analysis
4. Serological analysis
5. Genetic and molecular analysis
 - G + C base composition
 - DNA analysis using genetic probes
 - Nucleic acid sequencing and rRNA analysis

Bacterial Taxonomy Based on *Bergey's Manual*:

- classification based on genetic information –phylogenetic
- two domains: Archaea and Bacteria
- five major subgroups with 25 different phyla

Major groups of Microorganisms:

1. Bacteria: Bacteriology
2. Fungi: Mycology
3. Algae: Phycology
4. Virus: Virology
5. Protozoa: Protozoology

Chapter Two: Introduction to Bacteria (Bacteriology)

2.1 Shapes of Bacteria:

- Cocci
 - Chain = Streptococcus
 - Cluster = Staphylococcus
- Bacilli
 - Chain = Streptobacillus
- Coccobacillus
- Vibrio = curved
- Spirillum
- Spirochete
- Square
- Star

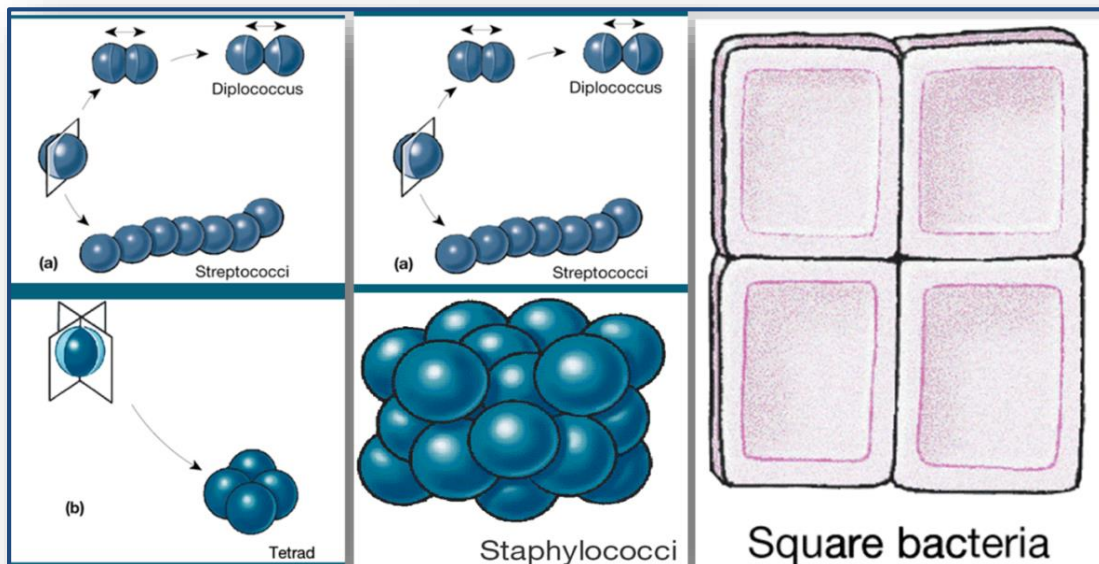
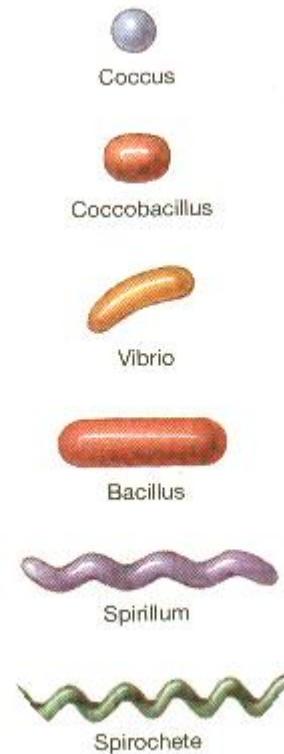

Different shapes of bacteria

2.2. Bacterial Cell Structures

- Flagella
- Pili
- Capsule
- Plasma Membrane
- Cytoplasm
- Cell Wall
- Lipopolysaccharides
- Teichoic Acids
- Inclusions
- Spores

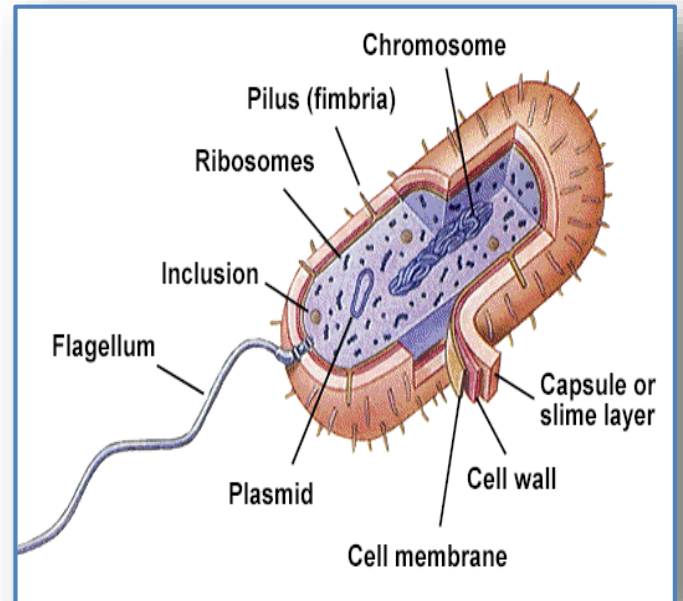

Flagella:

- Motility - movement
- Arrangement basis for classification
 - **Monotrichous:** 1 flagella
 - **Lophotrichous:** tuft at one end
 - **Amphitrichous:** both ends
 - **Peritrichous:** all around bacteria

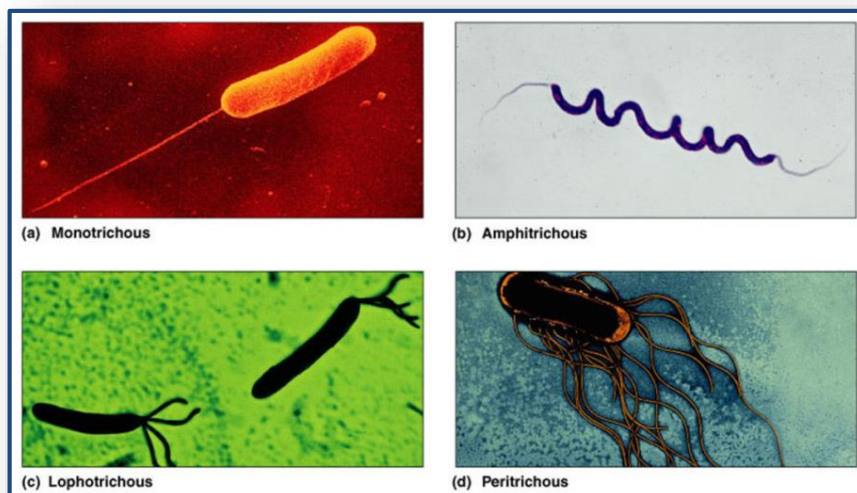

Flagella Arrangement

2.3. Bacterial Growth

Culture: Increase in the population of cells

Generation time: The time cell takes to divide (double) is called

Reproduction: Binary Fission

- Division exactly in half
- Most common means of **bacterial reproduction**
- Forming two equal size progeny
- Genetically identical offspring
- Cells divide in a geometric progression doubling cell number

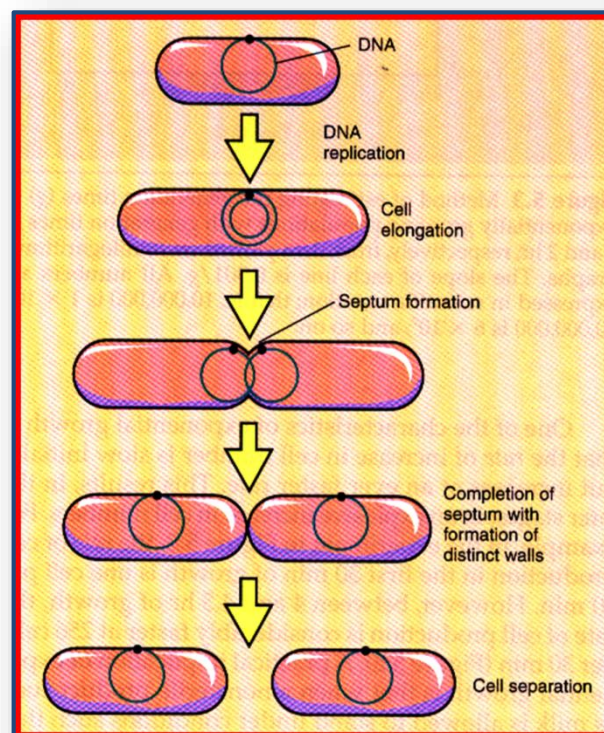

Binary Fission: Doubling time is the unit of measurement of microbial growth

2.4. Bacterial Culture Growth

Growth of culture goes through **four phases** with time:

1. Lag phase:

- Organisms are **adapting** to the **environment**
- **Synthesizing** DNA, ribosomes and enzymes in order to breakdown nutrients, and to be used for growth
- Little or **no division**

2. Log or Logarithmic phase

- Division is at a **constant rate**

3. Stationary phase:

- **Dying** and **dividing** organisms are at an **equilibrium**
- Death is due to **reduced** nutrients, pH changes, toxic waste and reduced oxygen
- Cells are smaller and have fewer ribosomes

4. Death or Decline phase

- The population is dying in a geometric fashion so there are **more deaths** than **new cells**
- Deaths are due to sever **reduced** nutrients, pH changes, toxic waste and reduced oxygen

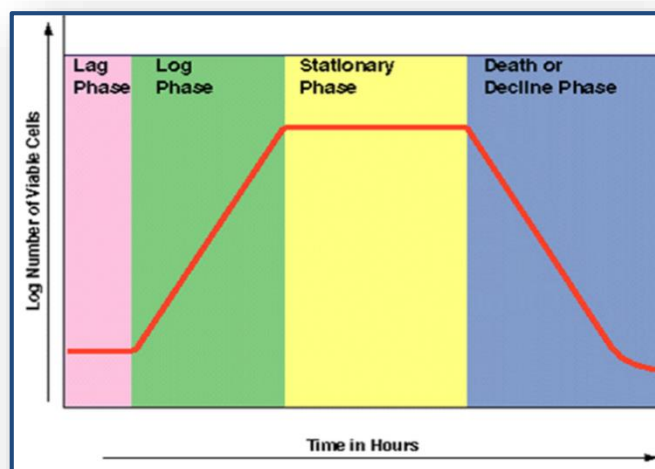

Bacterial Growth Curve

2.5. Factors Influencing Bacterial Growth

Nutrition, Temperature, Oxygen, Salinity, pH, Pressure, Radiation

Nutrition:

Source of Energy:

- Bacteria are found in almost every environment because they can use widely different energy sources.
- Based on their energy source bacteria can be grouped into 4 major types
 - **Photosynthetic Bacteria:** (1) Photoautotrophs and (2) Photoheterotrophs
 - **Chemosynthetic Bacteria:** (3) Chemoautotrophs and (4) Chemoheterotrophs

Basic bacterial requirements:

Water: Used to dissolve materials to be transported across the cytoplasmic membrane

Carbon: required for the construction of all organic molecules

- **Autotrophs** use inorganic carbon (CO₂) as their carbon source
- **Heterotrophs:** use organic carbon

Nitrogen: Obtained from:

- **Inorganic source:** e.g. Nitrogen gas (N₂), Nitrate (NO₃), Nitrite(NO₂), and Ammonia (NH₃)
- **Organic source:** e.g. Proteins, broken down to amino acids
- Many organisms use nitrogen gas by nitrogen fixation to produce ammonia

Other nutrients: Required in small amounts such as Iron, Sulfur, and Phosphorus

Nutritional Patterns:

Table 27.1 Major Nutritional Modes			
Mode of Nutrition	Energy Source	Carbon Source	Types of Organisms
Autotroph			
Photo-autotroph	Light	CO ₂	Photosynthetic prokaryotes, including cyanobacteria; plants; certain protists (algae)
Chemo-autotroph	Inorganic chemicals	CO ₂	Certain prokaryotes (for example, <i>Sulfolobus</i>)
Heterotroph			
Photo-heterotroph	Light	Organic compounds	Certain prokaryotes
Chemo-heterotroph	Organic compounds	Organic compounds	Many prokaryotes and protists; fungi; animals; some parasitic plants

Copyright © Pearson Education, Inc., publishing as Benjamin Cummings.

Bacterial Temperature Requirements

Psychrophiles: Some exist below 0 °C if liquid water is available eg. Oceans, refrigerators, and freezers

Mesophiles: Most human flora and pathogens.

Thermophiles: Hot springs, effluents from Laundromat, and deep ocean thermal vents

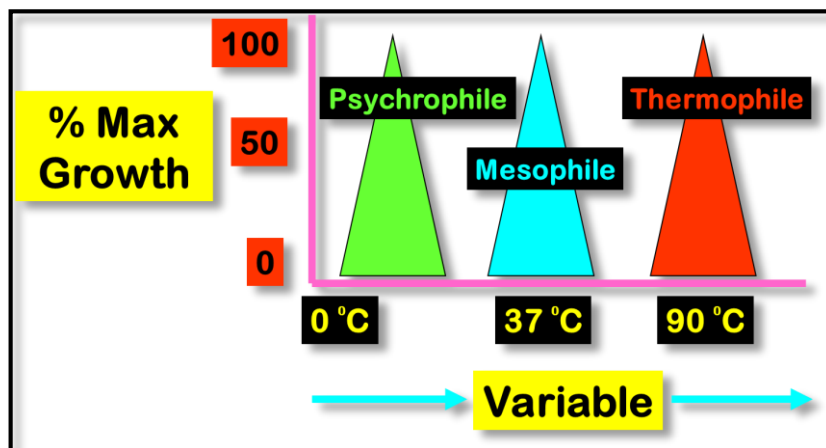

OXYGEN

- Required for aerobic respiration and energy production
- Organisms are classified according to their gaseous requirements
 1. Obligate aerobes
 2. Facultative anaerobes
 3. Obligate anaerobes

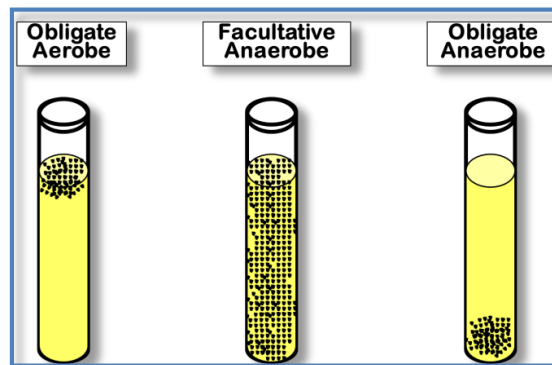

Salinity

Halophiles: Bacteria that specifically require NaCl for growth

Moderates Halophiles:

- Grow best at 3% NaCl solution
- Many ocean dwelling bacteria

Extreme Halophiles:

- Grow well at NaCl concentrations of greater than 15% e.g salt lakes, pickle barrels



Halophiles growing within salt lakes often turn the water pink

Bacterial pH Requirements

Microbes have different optimum pH requirements:

Acidophiles: Some bacteria can grow in acid substrates

Neutrophiles: most microbes prefer a pH near neutrality

Alkaliphiles: Microbes which can grow in very alkaline substrates

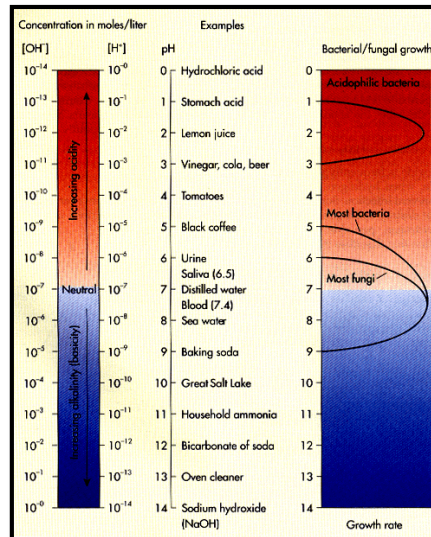

Bacterial pH requirements

2.6. Control of microbial growth

Sterilization: Removal or destruction of all microbial life forms

Physical Methods of Microbial growth Control:

1. Heat:

Moist heat:

- Coagulation (denaturing) of proteins
- Hydrogen bonds are broken

1.1. Boiling:

- Not always effective
- Kills most vegetative pathogens, viruses, fungi and spores within 10 minutes
- Some microbes resistant to boiling e.g. endospores (20 Hours)

1.2. Autoclave:

- Preferred method
- Moist heat (steam) and pressure
- **Limitations:** Material must be able withstand heat and moisture
- 15 psi (121° C) for 15 minutes will kill all organisms

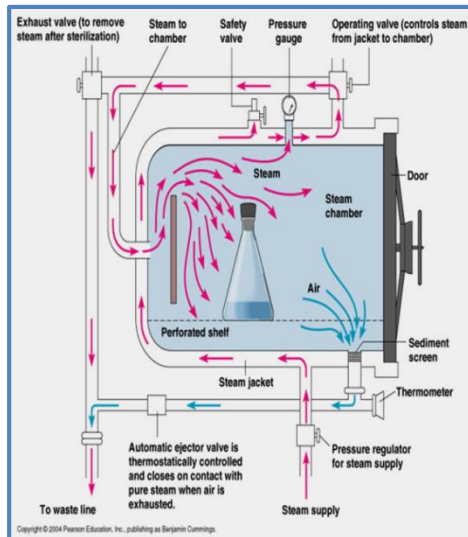

Autoclave

1.3. Pasteurization (Louis Pasteur):

- Mild heating (Initially 63° C for 30 minutes)
- Kills most pathogens and bacteria that cause spoilage
- Lowers bacterial numbers
- Preserves taste of product
- **High temperature short – time pasteurization (HTST)**
 - Kills pathogens
 - Lowers bacterial numbers, milk keeps while refrigerated

1.4. Dry Heat Sterilization

- Flaming
- Incineration
- Hot air sterilization: Placed in oven (170 ° C for 2 hours)

2. Filtration:

- Liquids and heat sensitive materials
- Filters composed of cellulose or plastic polymers. Vacuum assists gravity
- Small pores prevent passage of bacteria (0.1 μm - 1 μm)

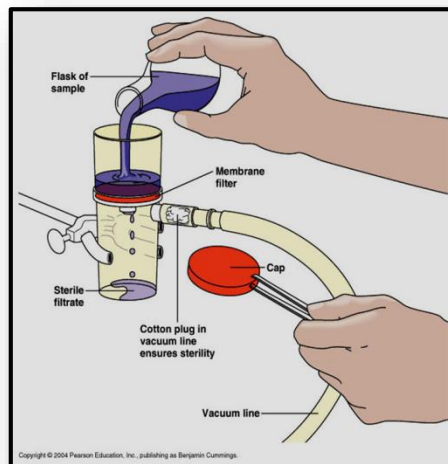

Sterilization by filtration

3. Low Temperatures (Refrigeration):

- Bacteriostatic (stop microbial growth)
- Psychrotrophs still present and grow
- Slow freezing more harmful to bacteria than rapid.
- Ice disrupts the cell structure
- Thawing damages bacteria as well

4. High Pressure:

- Applied to liquid suspensions
- Alters protein shape
- Endospores are resistant
 - Can be killed by altering pressure cycles
 - Endospores germinate then exposed to pressure again

5. Desiccation:

- Removal of water
- Microorganisms cannot grow but still survive
- Re-introduce water microorganisms **resume** growth and division
- Effectiveness varies between organisms
 - *Neisseria* withstand dryness for one hour
 - *Mycoplasma* withstand dryness for months
 - Endospores remain for centuries

6. Osmotic Pressure:

- High concentrations of **salt and sugar**
- Creates hypertonic environment
- Water leaves microbes cell
- Molds and yeasts can grow better than bacteria in high osmotic pressure or low moisture

7. Radiation:

- Ionizing radiation (gamma rays)
- High energy short wavelength
- Radioactive elements
- X-rays
- Penetrate deeply
- Require longer times
- Ionizes water to form hydroxyl radicals
- Food preservation in other countries

Chemical Methods of Microbial Growth Control:

Examples of some chemicals used for microbial growth control:

Chemical Agent	Mechanism of Action	Preferred Use	Comment
Alcohols	Protein denaturation and lipid dissolution.	Thermometers and other instruments; in swabbing the skin with alcohol before an injection, most of the disinfecting action probably comes from a simple wiping away (degerming) of dirt and some microbes.	Bactericidal and fungicidal, but not effective against endospores or nonenveloped viruses; commonly used alcohols are ethanol and isopropanol.
Heavy Metals and Their Compounds	Denaturation of enzymes and other essential proteins.	Silver nitrate may be used to prevent gonorrheal ophthalmia neonatorum; mercurochrome disinfects skin and mucous membranes; copper sulfate is an algicide.	Heavy metals such as silver and mercury are biocidal.
Surface-Active Agents			
1. Soaps and acid-anionic detergents	Mechanical removal of microbes through scrubbing.	Skin degerming and removal of debris.	Many antibacterial soaps contain antimicrobials.
2. Acid-anionic detergents	Not certain; may involve enzyme inactivation or disruption.	Sanitizers in dairy and food-processing industries.	Wide spectrum of activity; nontoxic, noncorrosive, fast-acting.

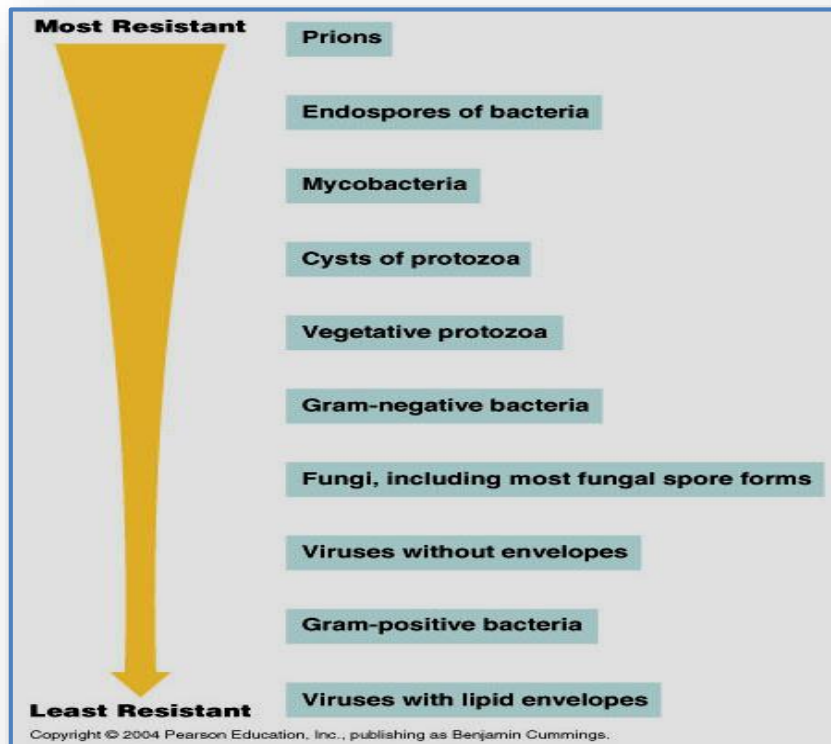

Chapter Three: Introduction to Fungi (Mycology)

The Study of Fungi is called Mycology

3.1. Main Characteristics of Fungi:

- Eukaryotic cells
- Non-photosynthetic (heterotrophic)
- Most fungi are **multicellular**
- Most fungi are microscopic **molds** or **yeasts**
- **Fungal cell wall:**
 - The cell walls of Fungi are made of **chitin** (polysaccharides)
 - Some fungi have cross walls, or **septa**, which divide the filaments into compartments having a single nucleus.
- Filaments of fungi are called hyphae.
- The **mycelium** is a mat of hyphae visible to the unaided eye (e.g. bread mold)
- Some hyphae may **divided** by cross sections called **septa**
- Some cells **lack septa** and are **multi-nucleated**, or coenocytic (have many nuclei)
- **The Primary Structures of a Fungi:**

• **Spores**
(haploid reproductive cell)

Hypha
(a single filament)

Mycelium
(a mass of hyphae)

Fruiting Body
(reproductive and dispersion)

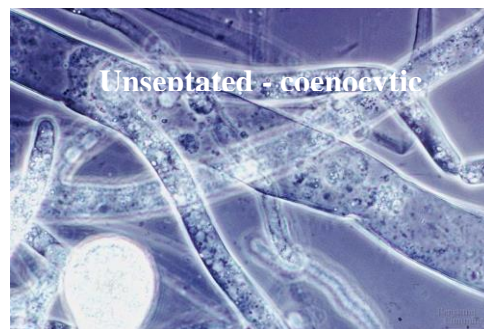

Structure of Fungi

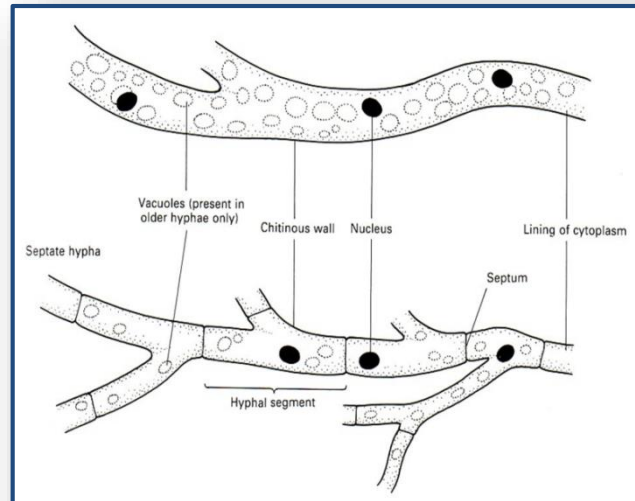

Structure of Fungi



The Mycelium growth in a Petri Dish

3.2. Fungi Reproduction:

- Fungi reproduce both **sexually** and **asexually**.
- Asexual reproduction includes:
 1. **fragmentation**: the breaking up of hypha
 2. **budding**: the pinching off of a small hypha outgrowth
 3. **asexual spores**: there's two kinds of asexual spores

- **Sporangiospores** are produced by **sporangia** which are located on top of a filament called a **sporangiophore**.
- **Conidia** are formed at the tips of specialized hyphae called **conidiophores**.

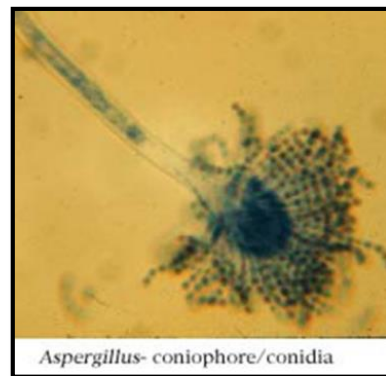
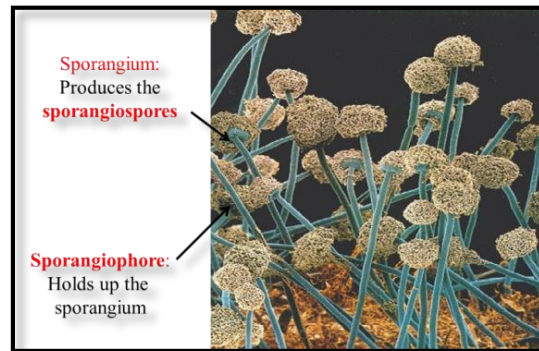

The Conidiophores look like tubes... the conidia look like small black dots inside the tubes

3.3. Classification of Fungi:

Fungi are mostly classified by the **shape** of the **reproductive structures (Fruiting Bodies)**

- **Phylum Zygomycota** (e.g. bread mold)
- **Phylum Basidiomycota** (e.g mushrooms, puff balls, bracket fungi)
- **Phylum Ascomycota** (cup fungi)
- **Phylum Deuteromycota** (Imperfect fungi)

1. Phylum Zygomycota:

- A common Zygomycota is **Bread Mold**
- Hyphae **lack septa**
- Sexual reproduction is by **conjugation** (fusing) hyphae from two different strains, followed by plasmogamy, karyogamy and meiosis and the production of Zygosporangia.

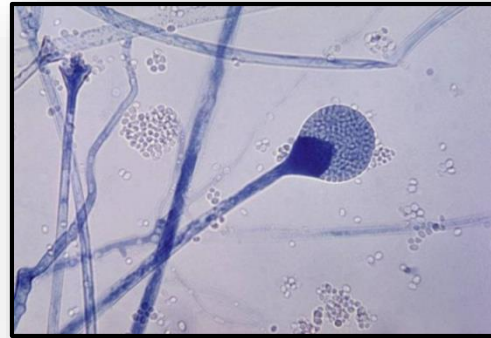
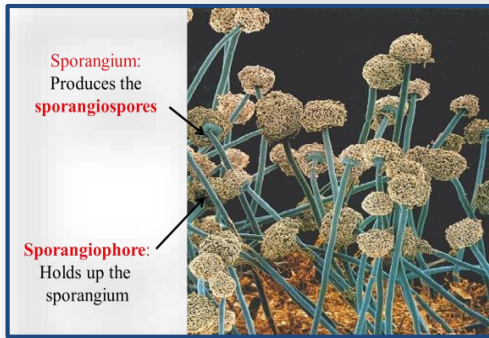

Asexual reproduction in Zygomycota

2. Phylum Basidiomycota:

- **Mushrooms, Puffballs, or Shelf (Bracket) Fungi**
- **Have Septa** and reproduce **sexually**
- Underground hyphae intertwine and grow upward to produce a reproductive structure called a **basidiocarp**. This basidiocarp is what we call a **mushroom**.
- Basidiospores are produced on the basidia, reproductive structures, which are found on the edges of the gills.



Agaricus

3. Phylum Ascomycota:

- The **largest** group of fungi
- Named for the reproductive **sacs** or **Asci** that form near the tips of the hyphae.
- **Ascospores** are formed here and released into the air when the ascus ruptures. These spores germinate to form new hyphae.



Cup Fungi

4. Phylum Deuteromycota:

- Athlete's Foot
- The Deuteromycetes (Imperfect Fungi)
- Fungi for which a **sexual** stage **has not been observed**.
- All reproduce by conidia
- Called "imperfect" because a sexual reproductive stage has not been observed.

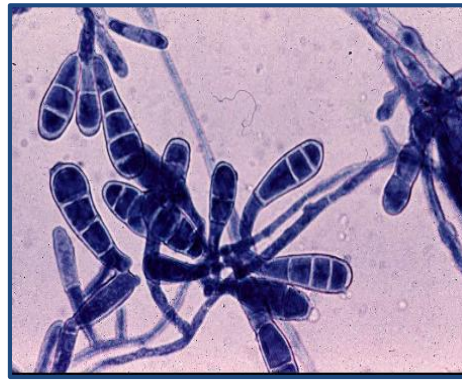
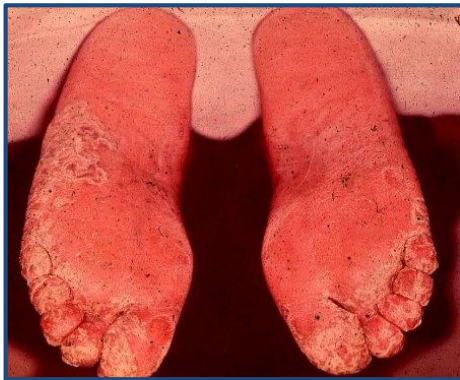

Athlete's Foot caused by *Epidermophyton floccosum*

3.4. Mode of life of fungi

1. Saprophyte:

- **Most** fungi are **saprophytes**, which break down dead matter and play a vital role in the **recycling of nutrients**.

- Extracellular Digestion – this is what is going on in our own stomachs except it is done outside of the body of the fungi. The resulting nutrients (smaller molecules of the original organic matter) are brought into the fungi through diffusion. The nutrients are then used for growth and repair.

2. Parasitic Fungi:

- These fungi can cause **diseases in plants and animals.**
- Examples: **athlete's foot** and ringworm (Tinea)
- These fungi feed on living cells. They have special hyphae (haustoria), that “drink” from the host cell without killing it immediately.



Plant and animal disease caused by fungi

3. Symbiotic Fungi:

Symbiosis is an **interaction** between **two organisms living together** in more or less intimate association or even the merging of two dissimilar organisms that bond and interact as a living element.

Mycorrhizas:

- **Mutualism** between **Fungus** (nutrient & water uptake for plant) and **Plant** (carbohydrate for fungus)
- Several kinds:
 - Zygomycota – hyphae invade root cells
 - Ascomycota & Basidiomycota – hyphae invade root but don't penetrate cells

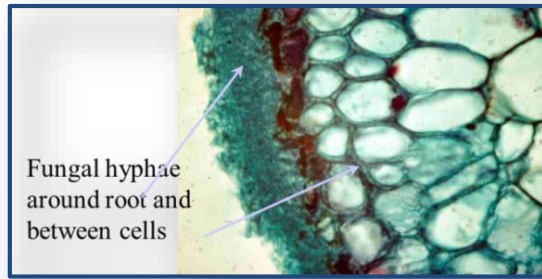

Mycorrhiza cross sections. Ecto”mycorrhizas

Lichens

- “**Mutualism**” between **Fungus** – structure and **Alga** or **cyanobacterium** – provides food
Form a thallus



Lichens

3.5. Human and Ecological Relevance of fungi

- ***Penicillium* Molds:**

Antibiotics production (Penicillin) & Gourmet Cheese

- ***Aspergillus:***

- Production of Citric Acid and Soy Sauce,
- Aspergilloses (Respiratory Disease), Aflatoxin (Carcinogen)

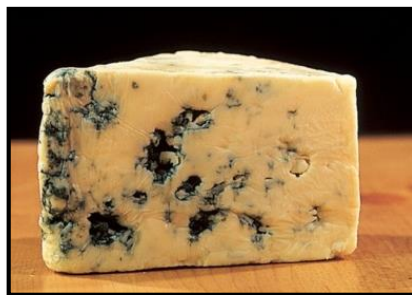

Gourmet Cheese

Chapter Four: Introduction to Algae (Phycology)

4.1. Characteristics of algae

- Algae have a **widespread** occurrence:
1. **Aquatic habitat:** marine, freshwater
 2. **Terrestrial habitat:** deserts, soils, trees, rocks, etc
 3. Some are **symbiotic**
 - e.g. lichen is a symbiotic alliance between a fungus and an alga.
 - e.g. Green Algae (zooxanthellae) live within reef building corals.
 - “Plant-like” seaweeds
 - **Lack true leaves, stems & roots**
 - May be filamentous, grow in **mats** or **crusts**, sheets, or **kelp**

Growth forms of algae:

- Algae take on a variety of forms both **microscopic** and **macroscopic**
- Unicellular; Colonies; Filaments; Multicellular thallus



4.2. Major groups of algae:

1. **Diatoms:** Bacillariophyta
2. **Red algae:** Rhodophyceae
3. **Brown algae:** Phaeophyceae
4. **Green algae:** Chlorophyta

1. Division: Bacillariophyta (Diatoms)

- Large group of algae (many unidentified). Relatively recently evolved group
- **Habitat:** Diatoms live in cool oceans
- **Structure:** mostly unicellular, have silica in their cell walls

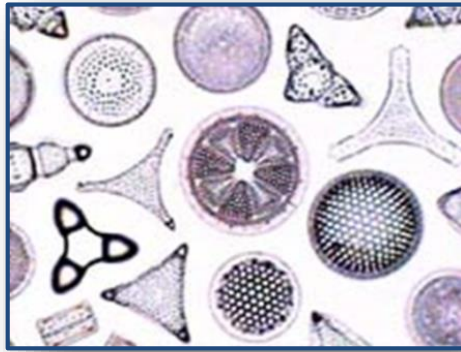

Diatoms

2. Division: Phaeophyta (brown algae)

- Brown/yellow pigment: **Fucxanthin** and **chlorophyll a & c**
- Diverse morphologies: Simple to large & complex up to **100 m**
- Fast growing kelp 1 to 2 feet a day
- Important source of **alginate**: Thickener, stabilizer, emulsifier in many products
- **Body form:** Thallus (plant-like but lacks true roots, stems and leaves)
- Thallus includes holdfast, stipe and leaflike blades
- Cell walls contain **cellulose** .

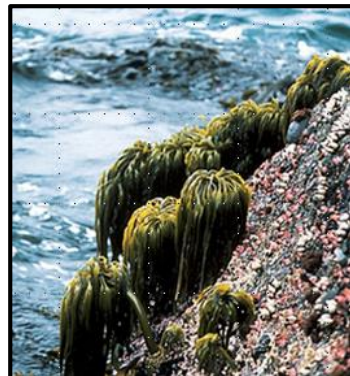

3. Division: Rhodophyta (Red algae)

- **Red pigments: Phycobilins and Chlorophyll a**
- Coralline algae
- Cell walls: **cellulose**, some with **CaCO₃**
- CaCO₃ in cell walls: **Defense** and structure
- Source of **carrageenan & agar** (emulsifiers & gel thickeners)
- ~ **5,500** species, mostly marine and few freshwater
- Live **attached** to **surfaces** (rocks, shells, other algae)
- Many are **reef-building** algae
- **Body forms:** Unicellular, simple filaments or complex filamentous aggregations



4. Division: Chlorophyta (Green algae)

- Green pigments: **Chlorophyll a & b**
- **Diverse morphologies:** Filamentous & Sheets & Spongy and Calcareous (Important component of coral reef environments)
- Fossil record: 1.5-2 BYA
- ~ 8,000 species (500 genera)
- Marine, freshwater, terrestrial.
- **Attached** or **planktonic**.

- Many species form symbiotic relationships with other organisms.
- Unicellular, filaments, colonies, also thallus body form.
- Cell walls: absent, cellulose, or modifications
- Many taxonomists believe green algae (and red algae) should be included among the Plantae.



Green algae

4.3. Ecological Importance of algae:

- Are very important primary producers especially in marine ecosystems
- Play major roles in global cycling of C, N, and O₂.
- Their photosynthetic activity forms the basis of complex communities.

Chapter Five: Introduction to Protozoa (Protozoology)

5.1. Characteristics of Protozoa:

- Unicellular Organization :Since Protozoa are single celled they often **rely** on **other organisms** for some necessities
- **Reproduction:**
 - **Asexual:**
 1. **Binary fission:** cytoplasmic division follows mitosis, producing two organisms
 2. Budding:
 3. **Multiple fission or schizogony:** cell or organism is split into many new cells or organisms
 - **Sexual**

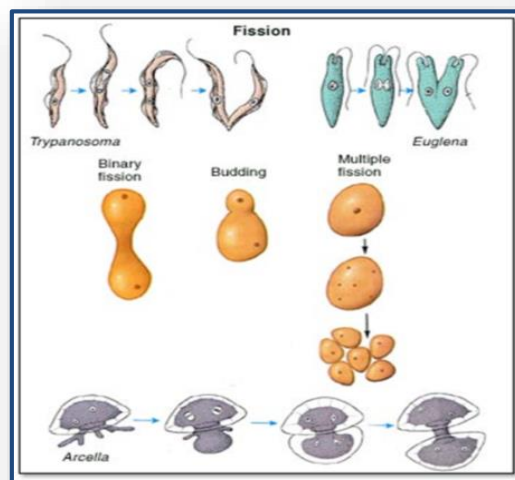

Reproduction in Protozoa

Symbiosis:

An intimate association between two organisms and there are three types of symbiosis:

1. **Parasitism:** one organism lives in or on a second organism, called the **host**. The host is harmed, but usually survives
2. **Commensalism:** one organism benefits and the other **neither benefits nor is harmed**
3. **Mutualism:** both organisms benefit from the relationship

5.2. Protozoan Taxonomy:

1. Phylum **Sarcomastigophora**

- Subphylum **Mastigophora**
- Subphylum **Sarcodina**

2. Phylum **Apicomplexa**

3. Phylum **Ciliophora**

1. Phylum Sarcomastigophora

Characteristics:

- 18,000 species, largest protozoan phylum
- Unicellular or Colonial
- **Locomotion** by flagella, pseudopodia, or both
- Autotrophic, saprozoic, or heterotrophic
- Single type of Nucleus
- **Sexual** Reproduction (usually)

Subphylum Mastigophora:

Locomotion is by one or more **flagella**

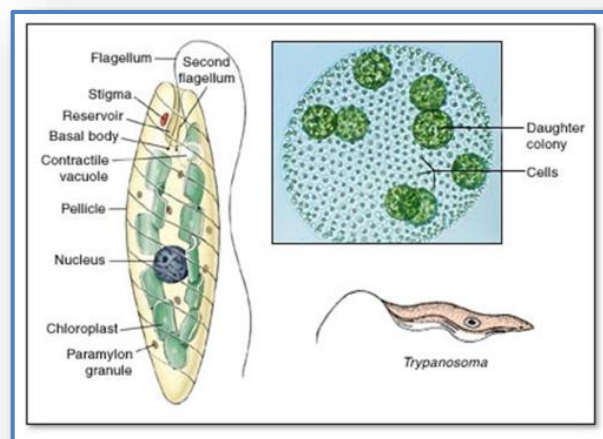

Subphylum Mastigophora

Subphylum Sarcodina:

- Locomotion and food gathered by *pseudopodia* (false foot)
- *Pseudopodia* is temporary cell extension used for movement and gathering food
- includes the Amoeba

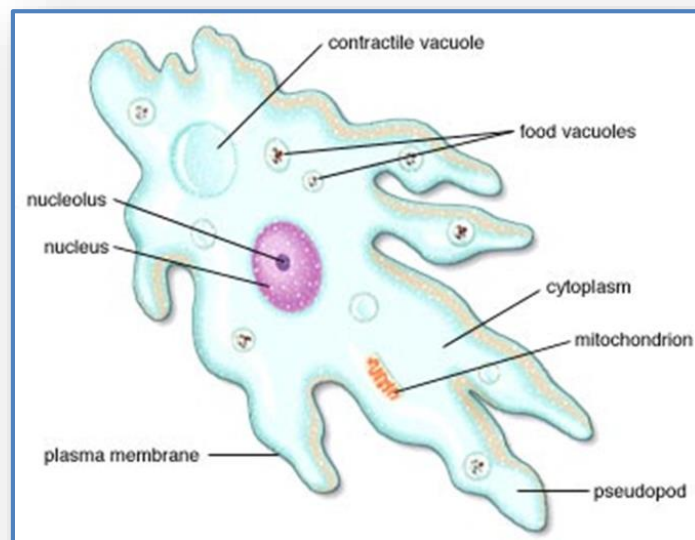

Amoeba

2. Phylum Apicomplexa:

Characteristics:

- All are **parasites**
- Apical complex for penetrating host cells
- **Single** type of Nucleus
- Usually **No Cilia** and Flagella
- Life cycles that typically include asexual and sexual phases

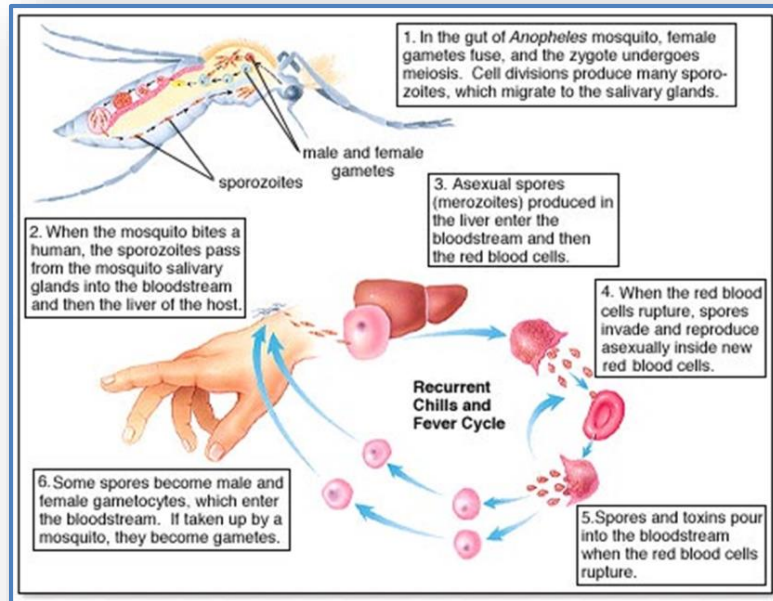

Malaria caused by Plasmodium

3. Phylum Ciliophora

Characteristics:

1. **Cilia** for **locomotion** and for the generation of feeding currents of water. Cilia are generally **similar to flagella** but **are much shorter**, more numerous and widely distributed over the surface of the organism
2. Relatively rigid pellicle and more or less fixed shape
3. Distinct cytostome (**mouth**) Structure
4. Dimorphic nuclei, typically larger macronuclei and one more smaller micronuclei
5. Some ciliates possess an **oral groove**
6. cilia sweep food particles down this groove toward the **cytopharynx** where a food vacuole forms
7. Some ciliates even possess an **anal pore** which is used to remove waste from the organism
8. Ciliate have **two** kinds of **nuclei**

- **Macronuclei:** large polyploid nucleus that regulates daily metabolic activities
 - **Micronuclei:** one or more small nucleus which are genetic reserve of the cell
9. Ciliates can reproduce asexually by **transverse binary fission** and occasionally by **budding**
10. Ciliates can reproduce **sexually** by **conjugation**

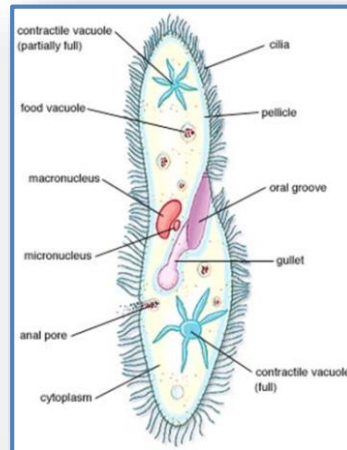

Conjugation

1. Random contact brings individuals of opposite mating types together (called conjugants)
2. **Meiosis** results in four haploid pronuclei
3. Three pronuclei and the macronucleus degenerate. Mitosis and mutual exchange of pronuclei is followed by fusion of the pronuclei.
4. Conjugants separate. Nuclear divisions that restore nuclear characteristics of species follow. Cytoplasmic divisions may accompany these events.

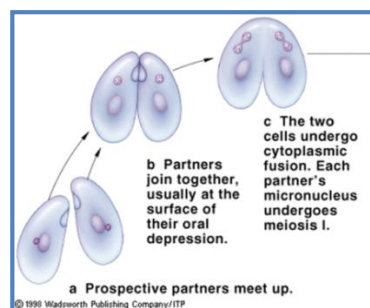

Conjugation

Chapter Six: Introduction to Virus (Virology)

6.1. Viral Characteristics

- Virus" is from the Greek meaning for "**poison**" and was initially described by **Edward Jenner in 1798**
- Virus is a **package** of **genetic** information protected by a **protein shell** for delivery into a **host** cell to be expressed and replicated
- Nucleic acid (**DNA** or **RNA**)
- Lack of **nuclear membrane** and external **cell wall**
- They have **very small genomes**, produce limited numbers of proteins and do not possess many intracellular systems ie they are parasites > intracellular replication

- **Viruses – three basic forms:**

1. Complex :

- Poxviruses :No capsid DNA surrounded by core membrane
- Bacteriophages :Complex capsid head and tail structures

2. Naked or non-enveloped:

Capsid which contains DNA or RNA

3. Enveloped

- Outer membrane
- Capsid which contains DNA or RNA

Viral structure:

- **Capsomeres** are structural subunits containing several proteins
- **Capsomeres** aggregate to produce the viral capsid.
- The viral capsid associates with the viral nucleic acid to produce a **nucleocapsid**
- Nucleocapsids are usually arranged in one of three ways
- Lipid envelopes are derived from cellular membranes

- Viruses are known to infect every cell type
- **Obligate** intracellular parasites
- Nanometers in size (20 -200 nm)
- Acellular
- No metabolic enzymes
- No machinery for protein production
- Have instructions for their own reproduction, but **not outside** of host cell

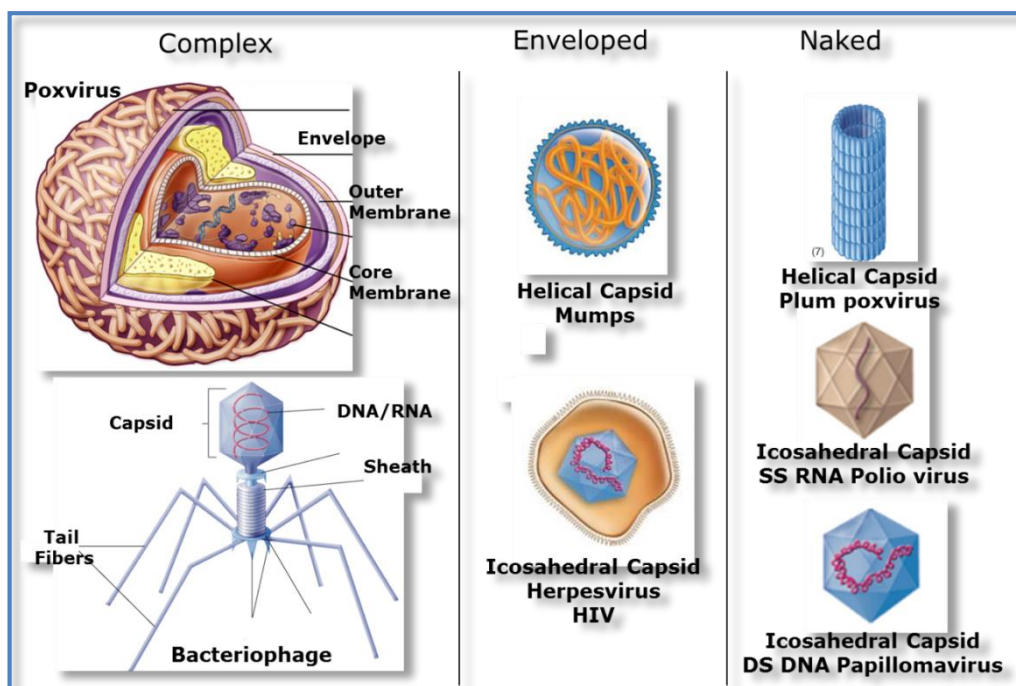

Viral structure:

6.2. Viral taxonomy:

Viral classification is based upon:

- Shape
- Type and form of nucleic acid
- Enveloped or naked
- Mode of replication
- Organization of the genome and antigenic differences

How are viruses classified?

- Hierarchical virus classification: Order- Family - subfamily - genus - species - strain/type
- All families have the suffix viridae, e.g Herpesviridae
- Genera have the suffix virus. For instance Coxsackie virus

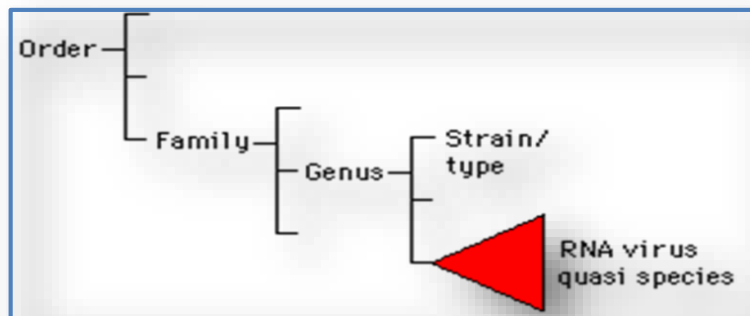

6.3. Genomic organization of viral nucleic acids:

1. RNA viruses

- RNA single stranded: positive polarity or negative polarity
- RNA double stranded: one piece or segmented

2. DNA viruses

- Single stranded
- Double stranded

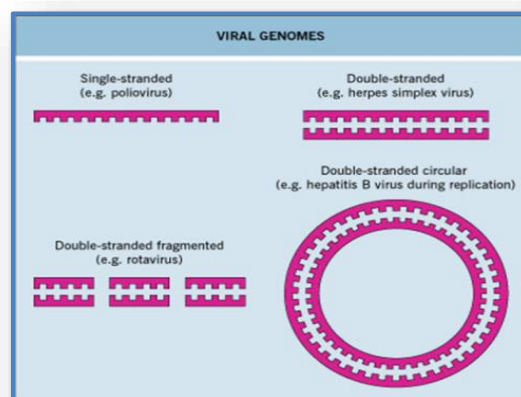

6.4. Viral Host Range:

- 1. Tropisms:** viral tissue specificities
- 2. Restricted:** Human liver cells – hepatitis B
- 3. Intermediate:** Intestinal and nerve cells of primates - poliovirus
- 4. Broad:** Various cells of all mammals – rabies

How do you acquire these viral infections?

- Direct personal contact: Herpes viruses, HIV, Influenza
- Airborne spread: Chicken pox
- Parenteral: HIV, Hepatitis B and C, cytomegalovirus (CMV)
- Fomites: Enteroviruses and other sturdy drying resistant viruses
- Vectors: West Nile
- Vertical transmission: HIV, Herpes simplex, cytomegalovirus, rubella (German measles)
- Enteral (foodborne): Hepatitis A, gastroenteritis viruses

6.5. Viral Life Cycles:

1. Adsorption/Docking:

Specific interactions

2. Penetration:

- Receptor mediated endocytosis
- Vesicle fuses with lysosome

3. Uncoating: Enzymes in lysosome digest capsid, envelope (if present) and release viral genome

4. Replication:

- Copies of viral genome
- Copies of viral proteins

5. Assembly:

- Viral capsid reforms
- Packaging of genome

6. Release:

- Budding taking pieces of host cell membrane
- Lytic host cell burst open releasing many virus particles

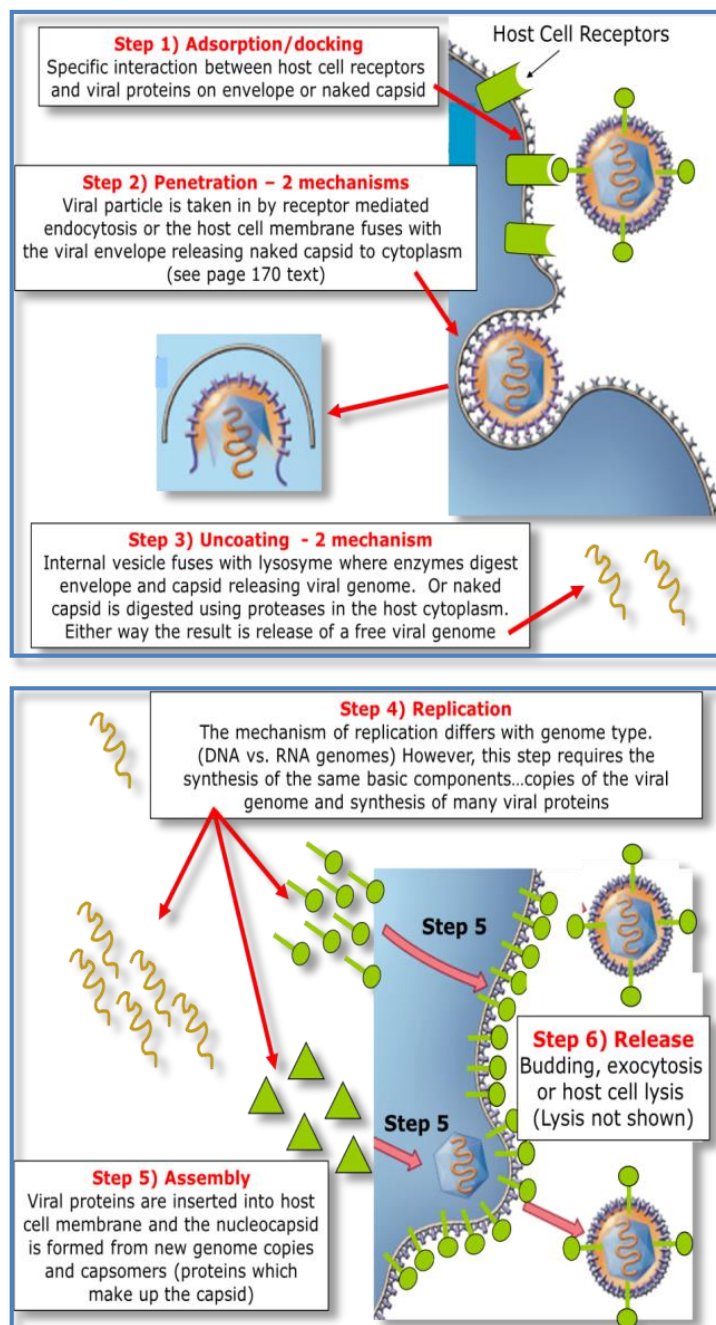

Life cycle of virus

Chapter Seven: Introduction to Microbial Metabolism

7.1. Metabolism:

- The sum of the chemical reactions in an organism
- A metabolic pathway is a sequence of enzymatically catalyzed chemical reactions in a cell.
- Metabolic pathways are determined by enzymes.
- Enzymes are encoded by genes.

1. Catabolism: The energy-releasing processes. Catabolism provides the building blocks and energy for anabolism

2. Anabolism: The energy-using processes

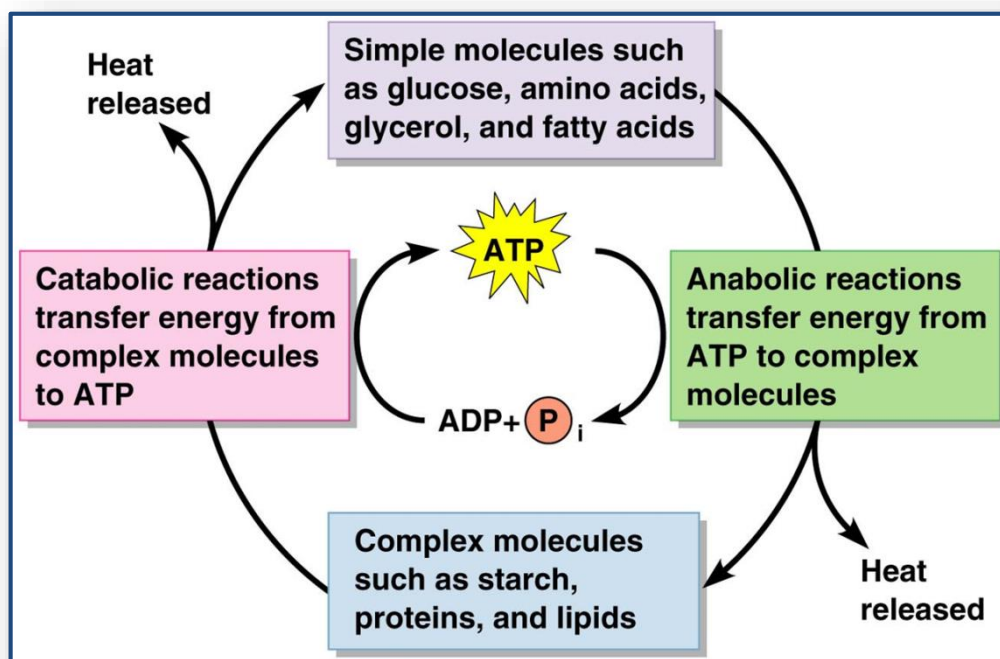

- The collision theory states that chemical reactions can occur when atoms, ions, and molecules collide .
- Activation energy is needed to disrupt electronic configurations.
- Reaction rate is the frequency of collisions with enough energy to bring about a reaction .

- Reaction rate can be increased by enzymes or by increasing temperature or pressure.

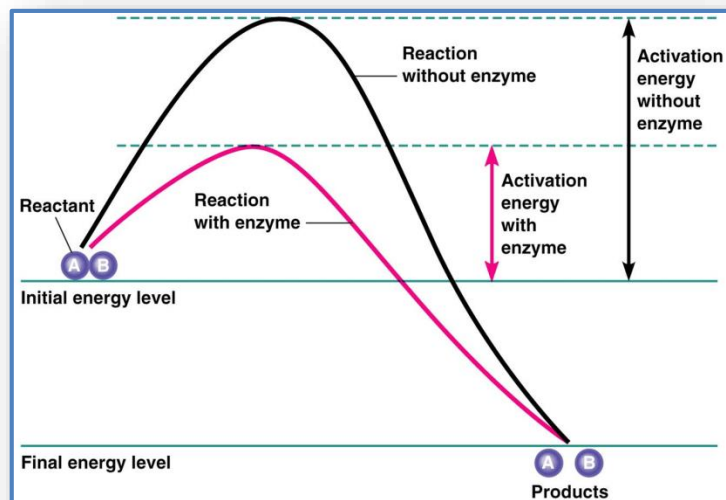

Enzyme

7.2. Enzymes:

- Biological **catalysts**
- Specific for a chemical reaction; not used up in that reaction
- **Apoenzyme:** Protein
- **Cofactor:** Nonprotein component

Coenzyme: Organic cofactor (NAD⁺, NADP⁺, FAD, Coenzyme A)

- **Holoenzyme:** Apoenzyme plus cofactor

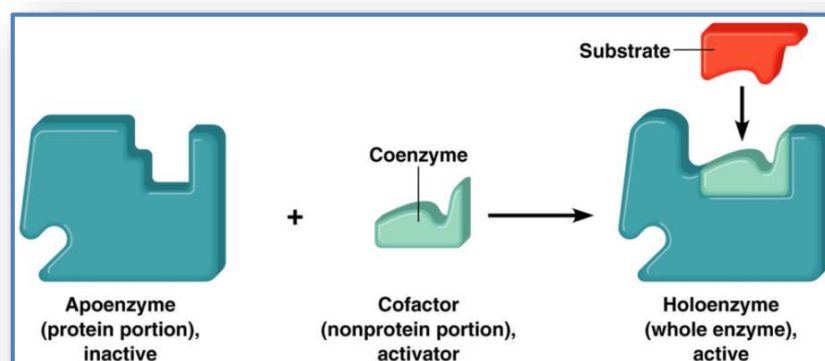

Key-Lock theory of enzyme activity

Enzyme Classification:

1. **Oxidoreductase:** Oxidation-reduction reactions
2. **Transferase:** Transfer functional groups
3. **Hydrolase:** Hydrolysis
4. **Lyase:** Removal of atoms without hydrolysis
5. **Isomerase:** Rearrangement of atoms
6. **Ligase:** Joining of molecules, uses ATP

Factors Influencing Enzyme Activity:

Enzymes can be denatured by temperature and pH

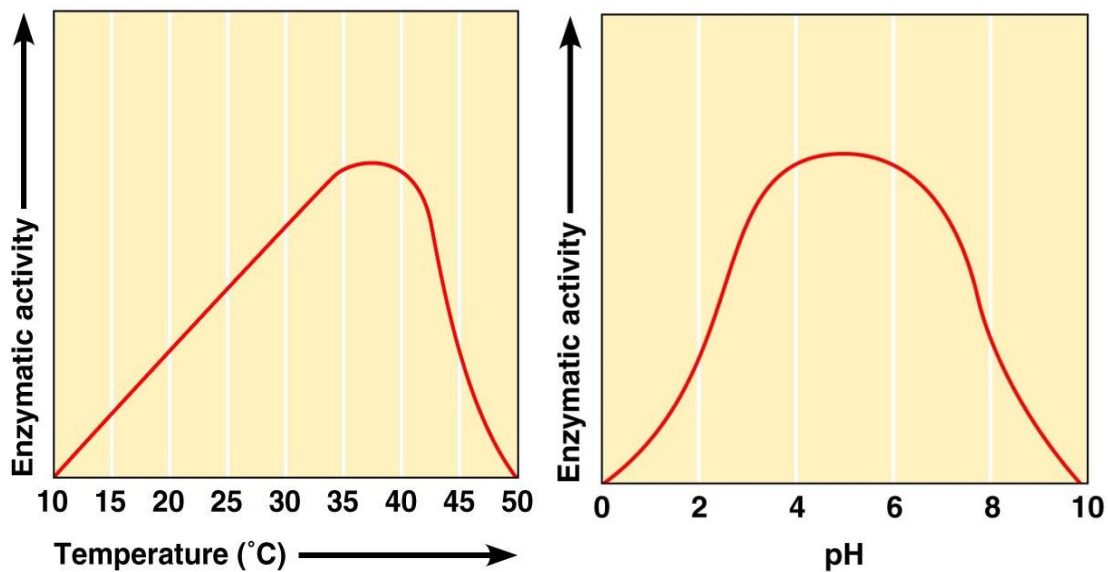
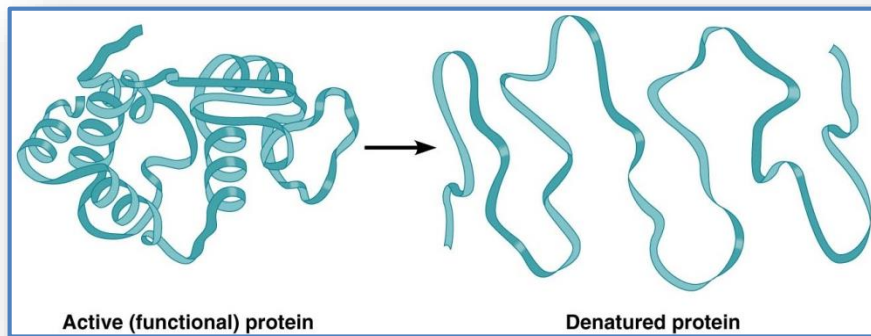

Factors Influencing Enzyme Activity

Oxidation-Reduction Reaction:

- Oxidation is the removal of electrons.
- Reduction is the gain of electrons.
- Redox reaction is an oxidation reaction paired with a reduction reaction.
- In biological systems, the electrons are often associated with hydrogen atoms. Biological oxidations are often dehydrogenations

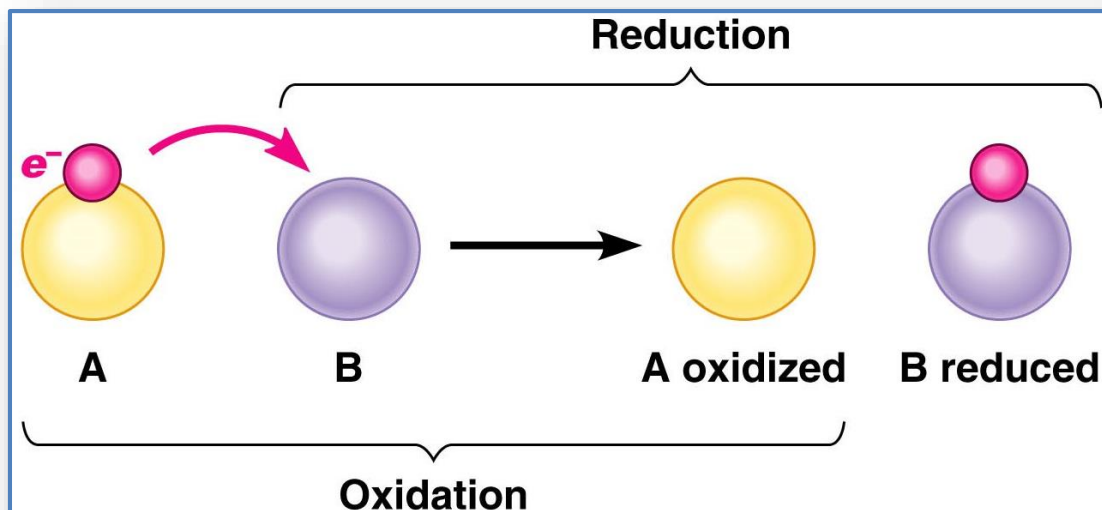

Oxidation-Reduction Reaction:

7.3. Carbohydrate Catabolism

The breakdown of carbohydrates to release energy which are carried out through three major processes:

1. **Glycolysis**
2. **Krebs cycle**
3. **Electron transport chain**

1. Glycolysis:

The oxidation of **glucose** to **pyruvic acid** produces ATP and NADH.

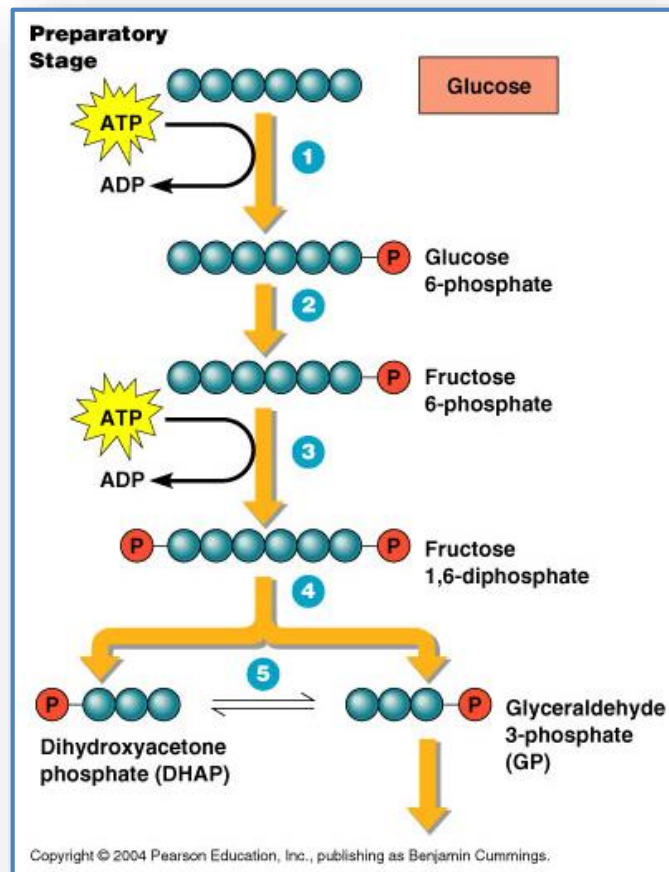
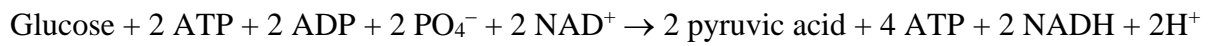

Glycolysis cycle

2. Krebs Cycle (Citric acid cycle):

Oxidation of **acetyl CoA** produces NADH and FADH₂

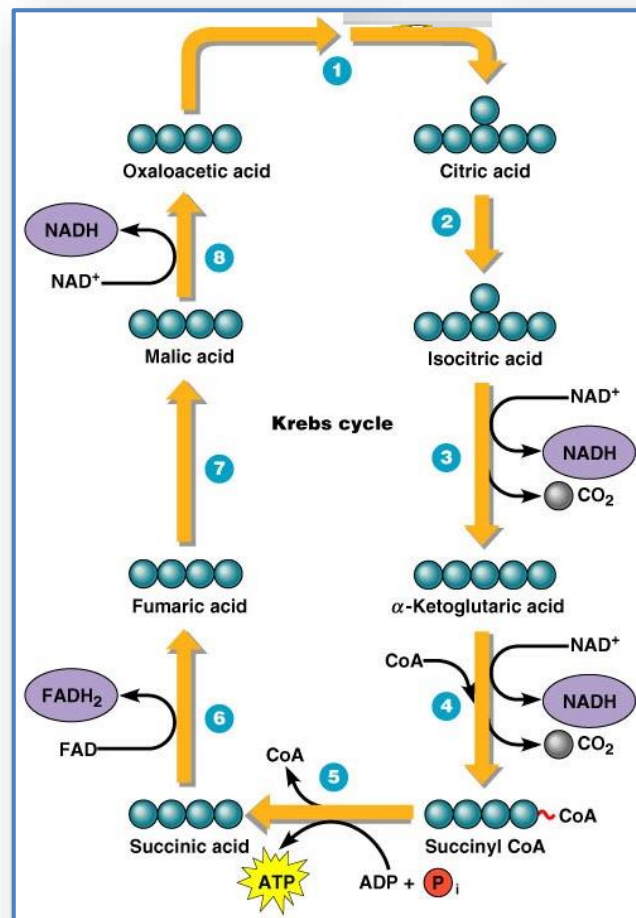

Krebs Cycle (Citric acid cycle):

3. Electron transport chain:

- Oxidation of molecules liberates **electrons** for an electron transport chain.
- ATP is generated by oxidative phosphorylation
- **Aerobic respiration:** The **final electron acceptor** in the electron transport chain is molecular **oxygen** (O₂)
- **Anaerobic respiration:** The **final electron acceptor** in the electron transport chain is not O₂ and it yields **less energy** than **aerobic** respiration because only part of the Krebs cycles operations under anaerobic conditions

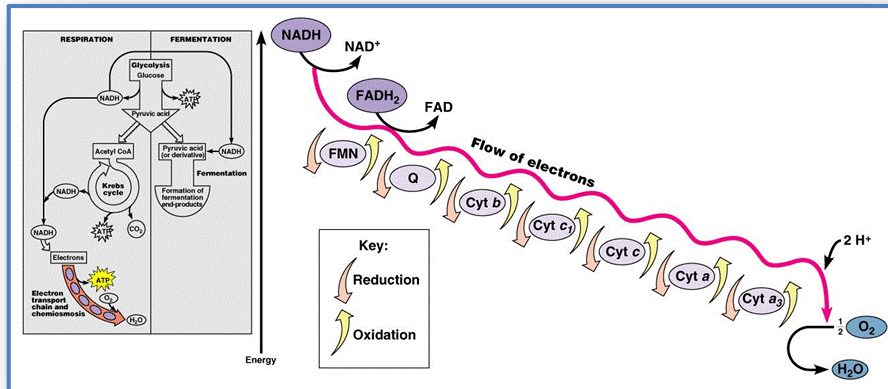

Electron transport chain

ATP produced from complete oxidation of one glucose using aerobic respiration:

36 ATPs are produced.

Pathway	By substrate-level phosphorylation	By oxidative phosphorylation	
		From NADH	From FADH
Glycolysis	2	6	0
Intermediate step	0	6	
Krebs cycle	2	18	4
Total	4	30	4

Fermentation

- Releases energy from oxidation of organic molecules
- Does not require oxygen
- Does not use the Krebs cycle or Electron transport chain (ETC)
- Uses an organic molecule as the final electron acceptor
- Alcohol fermentation: Produces ethyl alcohol + CO₂.
- Lactic acid fermentation: Produces lactic acid.
- Homolactic fermentation: Produces lactic acid only.
- Heterolactic fermentation: Produces lactic acid and other compounds.

7.4. Lipid Catabolism

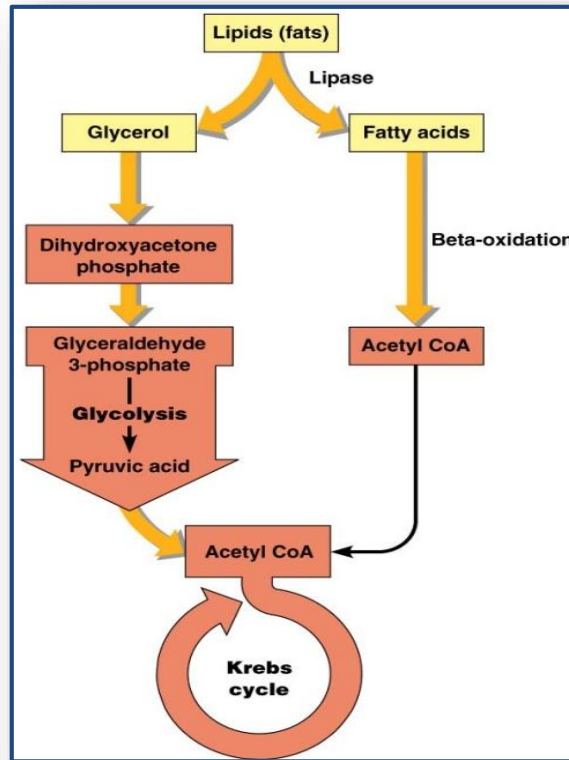

Protein Catabolism

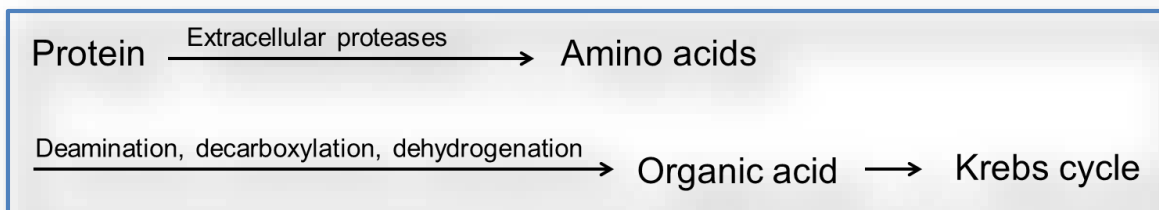

7.5. Photosynthesis

- Photo: Conversion of light energy into chemical energy (ATP)
- Light-dependent (light) reactions
- Synthesis: Fixing carbon into organic molecules
- Light-independent (dark) reaction, Calvin-Benson cycle
- Oxygenic:



- **Anoxygenic:**

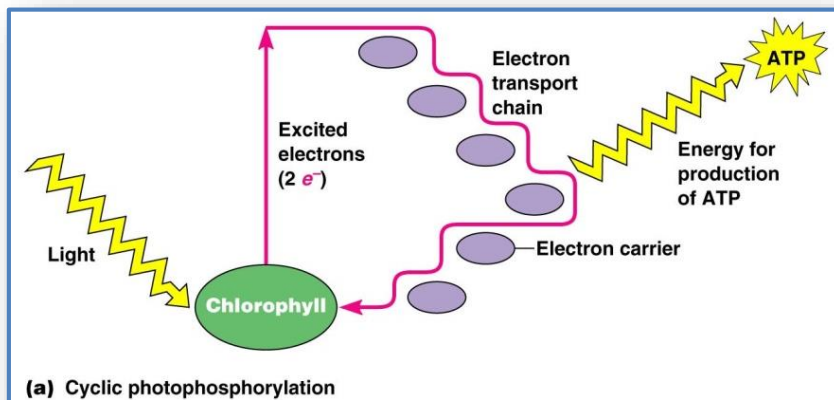

Cyclic Photophosphorylation

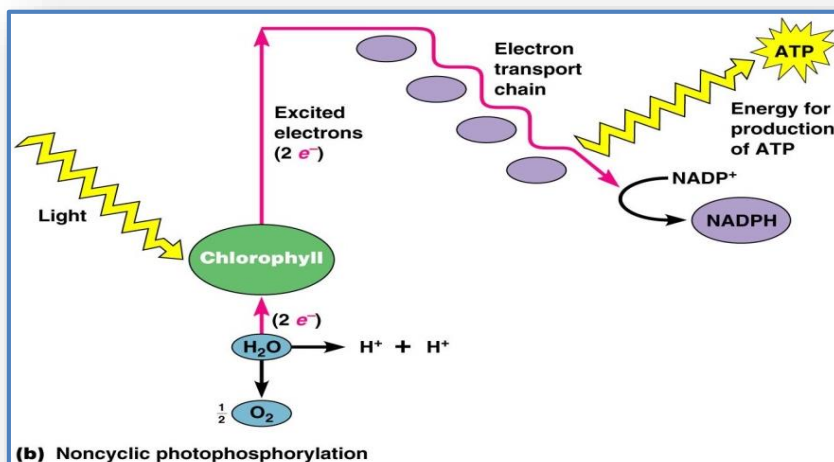

Non-Cyclic Photophosphorylation

7.6. Nutritional Categories of Microorganisms:

Microorganisms are often grouped according to the sources of energy they use:

1. **Phototrophs** use light as an energy source (Photosynthesis)
2. **Chemotrophs** use chemicals as energy sources

- Chemoorganotroph
- Chemolithotroph

Metabolic Diversity among Organisms:

Nutritional type	Energy source	Carbon source	Example
Photoautotroph	Light	CO ₂	Oxygenic: Cyanobacteria plants. Anoxygenic: Green, purple bacteria.
Photoheterotroph	Light	Organic compounds	Green, purple nonsulfur bacteria.
Chemoautotroph	Chemical	CO	Iron-oxidizing bacteria.
Chemoheterotroph	Chemical	Organic compounds	Fermentative bacteria. Animals, protozoa, fungi, bacteria.

Chapter Eight: Introduction to Microbial Genetics

- **Genetics:** The study of what genes are, how they carry information, how information is expressed, and how genes are replicated.
- **Gene:** A segment of DNA that encodes a functional product, usually a protein.
- **Genome:** All of the genetic material in a cell
- **Genomics:** The molecular study of genomes
- **Genotype:** The genes of an organism
- **Phenotype:** Expression of the genes

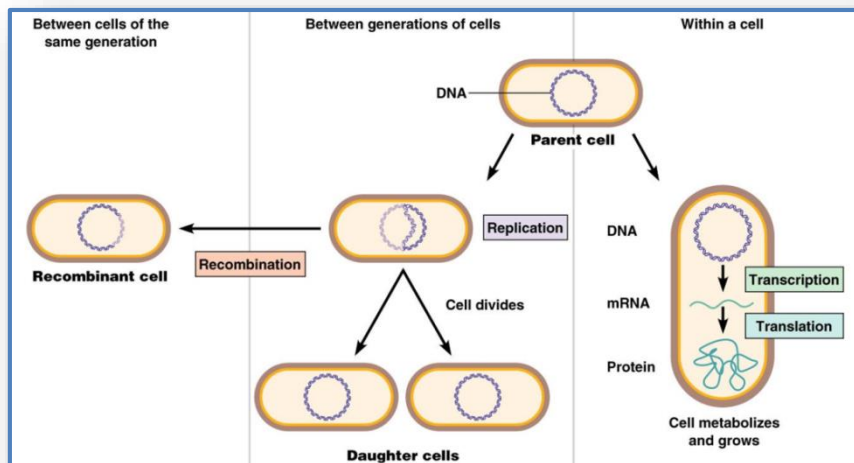

Flow of Genetic Information

Genetic Information Storage:

DNA/Base sequences

Genetic information transfer

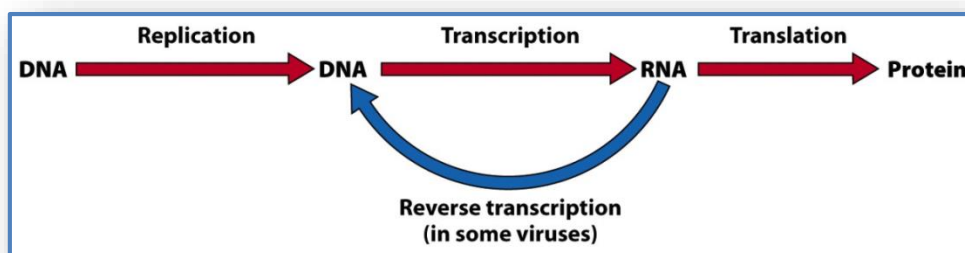

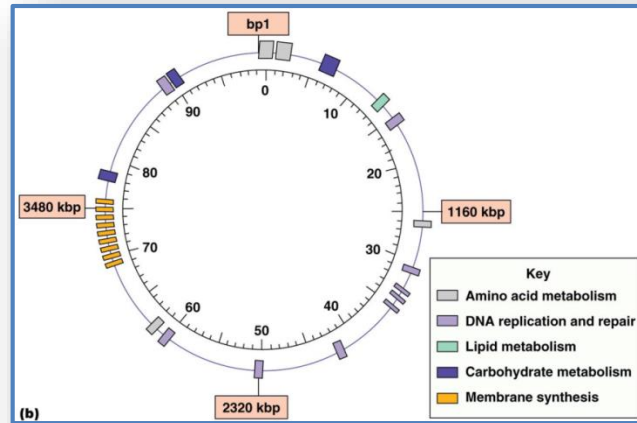

Chromosome Map

Deoxyribonucleic acid (DNA)

- Polymer of nucleotides: Adenine, thymine, cytosine, and guanine
- Double helix associated with proteins
- "Backbone" is deoxyribose-phosphate
- Strands are held together by hydrogen bonds between AT and CG.
- Strands are antiparallel.

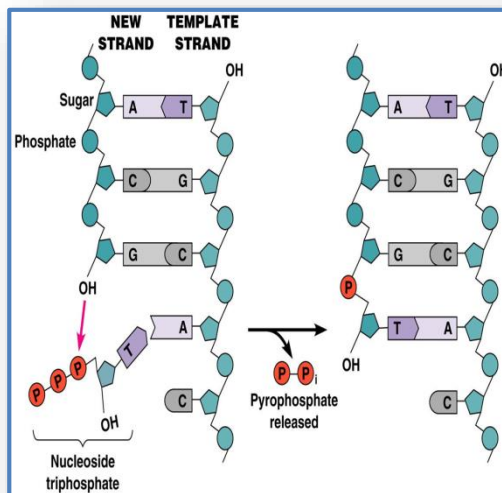
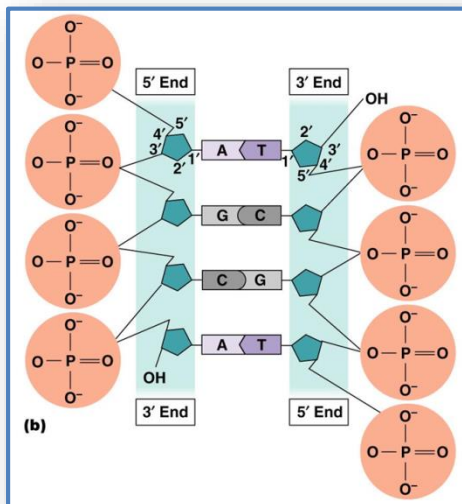

- DNA is copied by DNA polymerase in the 5'- 3' direction
- Initiated by an RNA primer
- Leading strand is synthesized continuously

- Lagging strand is synthesized discontinuously forming **Okazaki fragments**
- RNA primers are removed and Okazaki fragments joined by a DNA polymerase and DNA ligase

DNA Replication:

DNA replication is semiconservative.

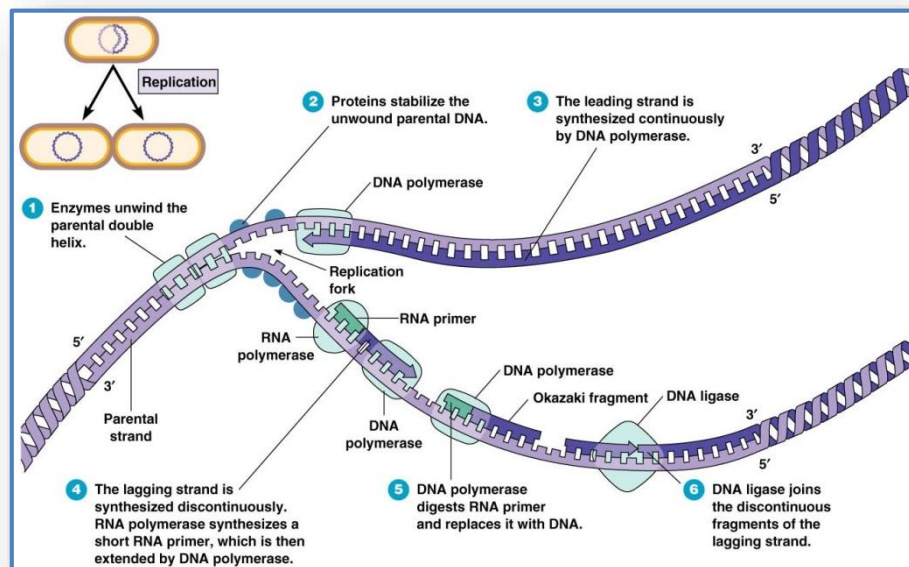

DNA Replication: DNA replication is semiconservative.

Synthesis of Protein

1. Transcription:

- DNA is transcribed to make RNA (mRNA, tRNA, and rRNA).
- Transcription begins when RNA polymerase binds to the promotor sequence
- Transcription proceeds in the 5' → 3' direction
- Transcription stops when it reaches the terminator sequence

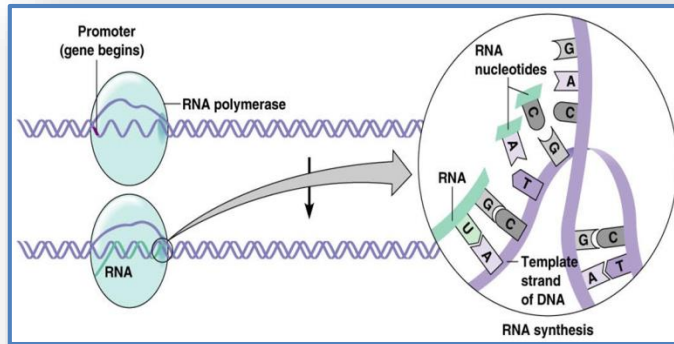
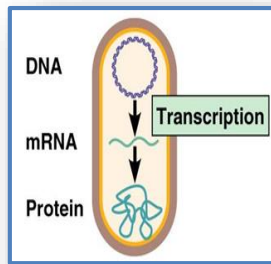

DNA Transcription process

2. Translation:

- mRNA is translated in codons (three nucleotides)
- Translation of mRNA begins at the start codon: AUG
- Translation ends at a stop codon: UAA, UAG, UGA

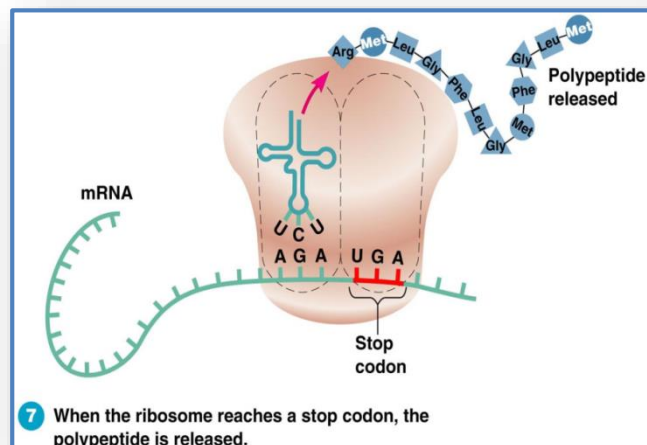
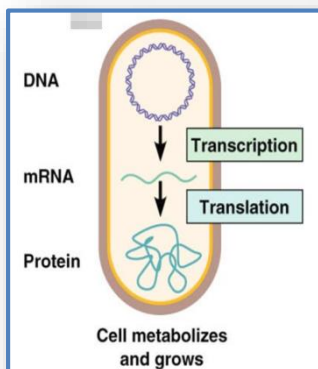

DNA Translation process

Mutation:

- A **change** in the **genetic** material
- Mutations may be **neutral**, **beneficial**, or **harmful**.
- **Mutagen:** Agent that causes mutations
- Spontaneous mutations: Occur in the absence of a mutagen

1. Base substitution (point mutation):

- Missense mutation
- Change in one base resulting in change in amino acid

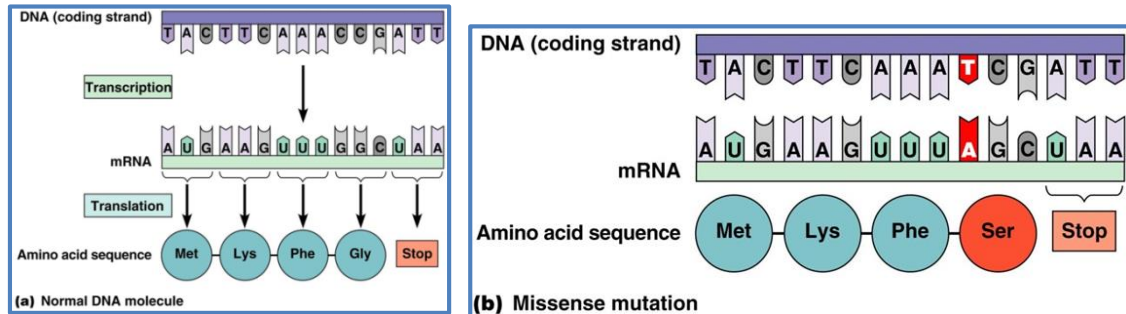

Base substitution (point mutation)

2. Nonsense mutation:

Results in a nonsense codon

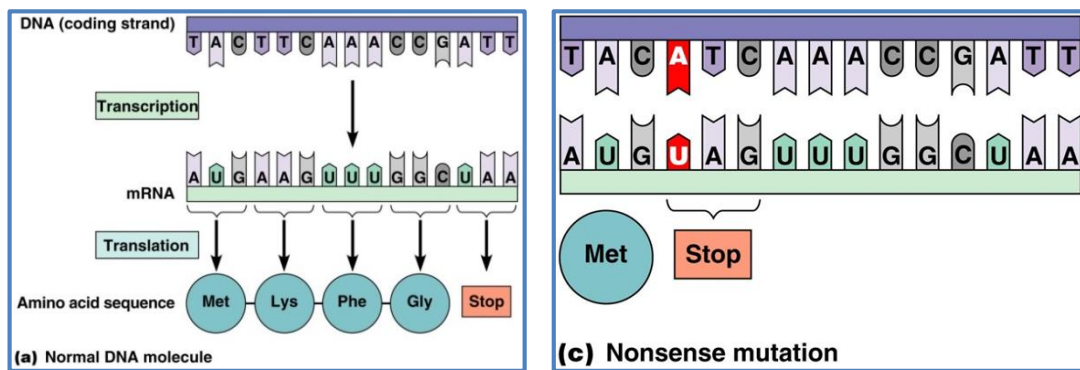

Nonsense mutation

3. Frameshift mutation:

Insertion or deletion of one or more nucleotide pairs

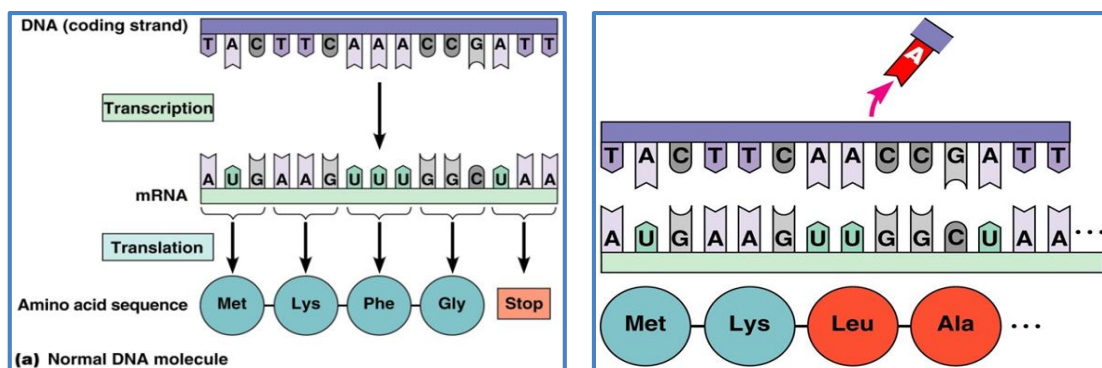

Frameshift mutation

Causes of mutations:

1. Spontaneous mutations

- Occur in the absence of mutation causing agents
- Due to occasional mistakes in DNA replication

2. Induced mutations:

- Caused by mutagens, agents such as chemicals and radiation which induce mutations
- Chemical mutagens:
 - Nitrous acid alters adenine such that it pairs with cytosine instead of thymine
 - Ethidium bromide inserts between bases causing frameshift mutation

- Radiation:

1. Ionizing radiation (Xrays and gamma rays)

Causes the formation of ions that can react with nucleotides (causing base changes) and the deoxyribose-phosphate backbone (causes chromosomes to break).

2. UV radiation

Induces formation of covalent bonds between adjacent thymines to form thymine dimers which can not be replicate

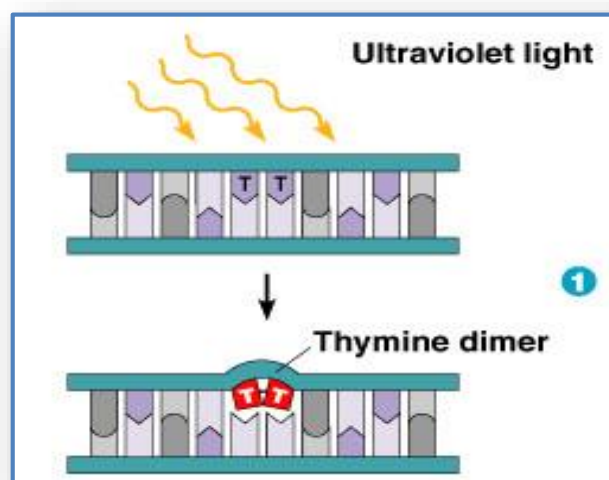

Chapter Nine: Introduction into Environmental Microbiology

- **Environmental Microbiology:** Studies the microorganisms as they occur in their natural habitats
- Microbes flourish in every habitat on Earth
- Microbes are important to the **cycling** of chemical elements
- **Microbial Ecology:** Study of the interrelationships among microorganisms and the environment
- **Two aspects to consider:**
 - Levels of microbial associations in the environment
 - Role of adaptation in microbial survival

Microbial Ecology:

- Role of adaptation in microbial survival
- Most microorganisms live in harsh environments
- Microbes must be specially adapted to survive
- Microbes must adapt to constantly varying conditions
- Extremophiles: Adapted to extremely harsh conditions

Biodiversity held in balance by various checks:

1. Competition
2. Antagonism
3. Cooperation

9.1. Soil Microbiology

- Examines the roles played by organisms living in soil
- Nature of soils
 - Soil arises from the weathering of rocks
 - Soil also produced through the actions of microorganisms

Environmental factors affecting microbial abundance in soils:

- 1. Moisture content:** Moist soils support microbial growth better than dry soils
- 2. Oxygen:** Moist soils are lower in oxygen than dry soils (Oxygen dissolves poorly in water)
- 3. pH:** Highly acidic and highly basic soils favor fungi
- 4. Temperature:** Most soil organisms are mesophiles
- 5. Nutrient availability:** Microbial community size determined by how much organic material is available

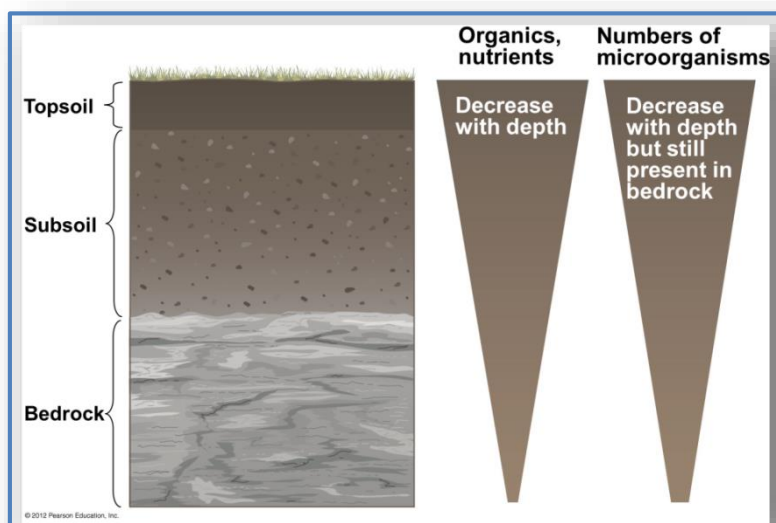

The soil layers and the distributions of nutrients and microorganisms within them

Microbial populations present in the soil include:

- Bacteria
- Archaea
- Fungi
- Algae and protozoa

Microbes perform a number of functions:

- Cycle elements and convert them to usable form
- Degrade dead organisms
- Produce compounds with potential human uses

Table 1: Selected Soilborne Diseases of Humans and Plants

Selected Soilborne Diseases of Humans and Plants		
Microorganism	Host	Disease
Bacteria		
<i>Bacillus anthracis</i>	Humans	Anthrax
<i>Clostridium tetani</i>	Humans	Tetanus
<i>Agrobacterium tumefaciens</i>	Plants	Crown gall disease
<i>Ralstonia solanacearum</i>	Plants	Potato wilt
<i>Streptomyces scabies</i>	Plants	Potato scab
Fungi		
<i>Histoplasma capsulatum</i>	Humans	Histoplasmosis
<i>Blastomyces dermatitidis</i>	Humans	Blastomycosis
<i>Coccidioides immitis</i>	Humans	Coccidioidomycosis
<i>Polymyxa</i> spp.	Plants	Root rot in cereals
<i>Fusarium oxysporum</i>	Plants	Root rot in many plants
<i>Phytophthora cinnamomi</i>	Plants	Potato blight; root rot in many plants
Viruses		
<i>Hantavirus</i>	Humans	<i>Hantavirus</i> pulmonary syndrome
<i>Tobacco mosaic virus</i>	Plants	Necrotic spots in various plants
<i>Soilborne wheat mosaic virus</i>	Plants	Mosaic disease in winter wheat and barley

Rhizosphere:

Soil in direct contact with plant root is enriched in nutrients as a result of nearby plant activities

Organic material in rhizosphere:

1. **Exudates:** low molecular weight compounds released from plant cells in a non-metabolic manner (leakage)
2. **Secretions:** compounds metabolically released from plant cells
3. **Lysates:** compounds released from moribund cells during autolysis
4. **Plant mucilage: plant polysaccharides**

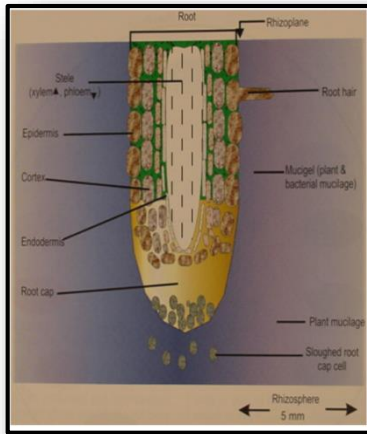

TABLE 18.1 Numbers of Microorganisms in the Rhizosphere (R) of Wheat (*Triticum aestivum*) and Nonrhizosphere Soil (S) and Their Resultant R/S Ratio

Microorganisms	Rhizosphere	Nonrhizosphere	R/S ratio
	CFU ¹⁰ g soil		
Bacteria	120×10^7	5×10^7	24.0
Fungi	12×10^5	1×10^5	12.0
Protozoa	2.4×10^3	1×10^3	2.4
Ammonifiers	500×10^6	4×10^6	125.0
Denitrifiers	1260×10^5	1×10^5	1260.0

Densities of microorganisms in rhizosphere

Beneficial of root-microbe interactions:

- Atmosphere contains 1015 tons N₂ gas
- Biological nitrogen fixation
- Minimum of 70 million tons N fixed/year

Symbiotic Relationships: Both host and parasite benefit

- Ex. Rhizobia (Symbiont) and Legumes (Host)
- Rhizobia: sugars, proteins, and oxygen
- Plant: usable nitrogen
- Biological nitrogen fixation: $N_2 + 3H_2 \rightarrow 2NH_3$

Enhancing the Symbiosis:

Natural symbiosis is reasonably effective:

- Free-living nitrogen fixation gives 25kg/hectare/year
- Symbiotic nitrogen fixation gives 100kg/hectare/crop

Current enhancements:

Application of rhizobial inoculants

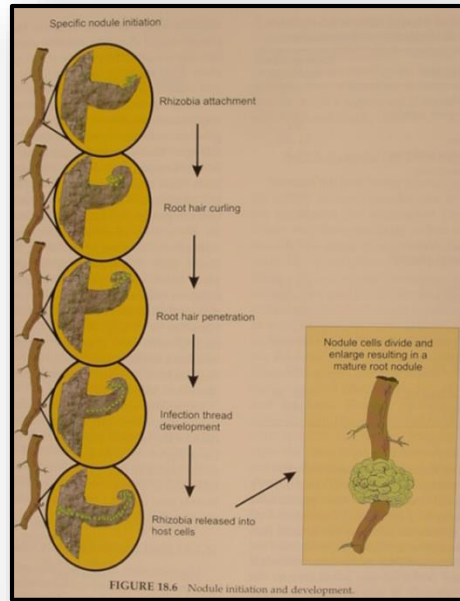
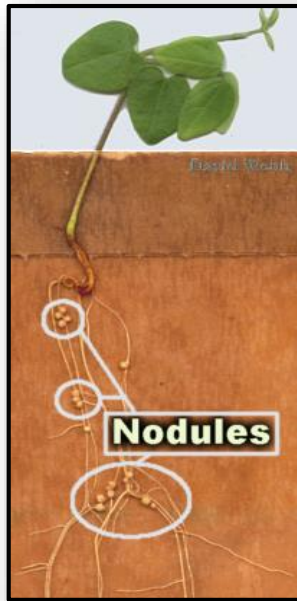

Nodule initiation and development

9.2. Aquatic Microbiology

- **Aquatic Microbiology:** Study of microbes living in freshwater and marine environments
- Ecology of aquatic environments is complex
- Most aquatic environments are teeming with life
- Water ecosystems support fewer microbes than soil due to dilution of nutrients
- Marine system constitute about 70% of the total Earth area
- **Types of aquatic habitats:**
 1. Freshwater systems – characterized by low salt content
 2. Marine systems – characterized by a salt content of ~3.5%
 3. Specialized aquatic systems – salt lakes, iron springs, and sulfur springs

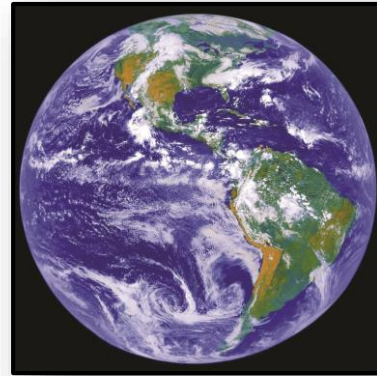
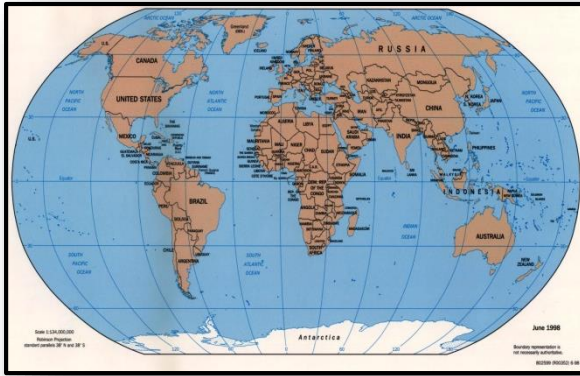

Marine system constitute about 70% of the total Earth area

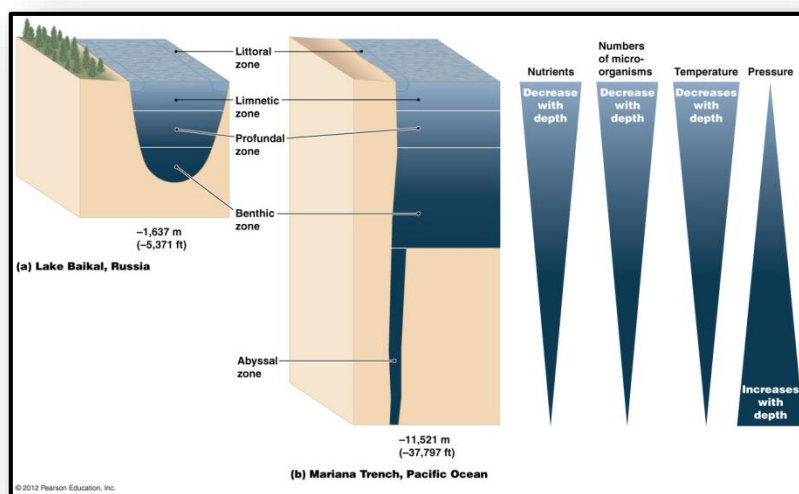

Vertical zonation in deep bodies of water-overview

Typical Water Quality Standards:

1. **Drinking Water (Potable):** No coliforms contamination acceptable
2. **Recreational water:** 200 fecal coliforms /100 ml
3. **Fish and wildlife habitat:** 5000 fecal coliforms/100 ml
4. **Shellfish:** 14 fecal coliforms/100 ml

Pathogens of most concern on fresh Produce:

Bacteria:

Salmonella, Shigella, Escherichia coli, Campylobacter, Yersinia enterocolitica, Staphylococcus aureus, Clostridium, Bacillus cereus, Vibrio

Viruses: Hepatitis A, Norwalk

Parasites/Protozoa: *Giardia*, *Entamoeba*, *Toxoplasma*, *Sarcocystis*, *Isospora*,
Cryptosporidium, *Eimeria*, *Cyclospora*



Vibrio sp

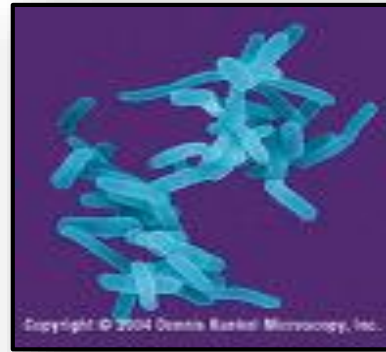



Shigella sp

Bacterial Indicator Organisms Common Groups:

- **General coliforms** – indicate water in contact with plant or animal life (universally present)
- **Fecal coliforms** – mammal or bird feces in water
- **Enterococcus bacteria** (type of fecal streptococci)– feces from warm blooded animals in water

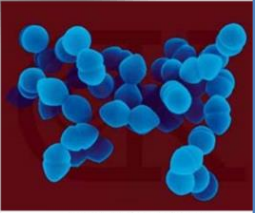
These are not what generally make people sick

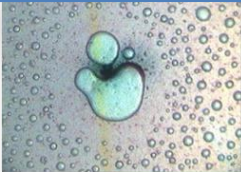

9.3. Air Microbiology (Aeromicrobiology)

- **Aerobiology** is defined as the study of life present in the air .
- **Aeromicrobiology** relates to the study of environmentally relevant microorganisms .
- Microorganisms exist within 300-1000 feet of earth's surface that have become attached to fragments of dried leaves, straw or dust particles light enough to be blown by wind .
- In dry weather the microbial load of air is high while in wet weather the rain washes the microorganisms from the air.
- Air is a poor medium for microbial growth – too dry and no nutrients
- Spore forming and Gram-positive bacteria are resistant to drying
- Dust, water droplets in air carry microbial populations from one place to another
- Sneezing, coughing, talking are efficient methods of transferring microbes from one respiratory tract to another
- Liquid and dust particles settle in the respiratory tract depending on their velocity and size
- Microorganisms colonize specific locations in the respiratory tract

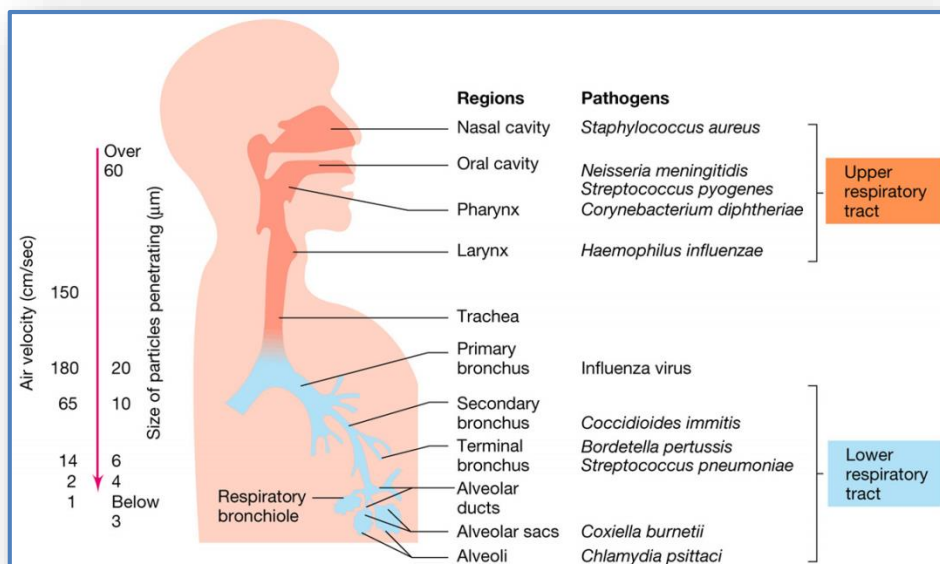

9.4. Food Microbiology

- Microorganisms are involved in producing many **foods** and **beverages**
- Fermentation produces desirable characteristics of various foods
- Microbial metabolism has other functions
 - Acts as a preservative
 - Destroys many pathogenic microbes and toxins
 - Can add nutritional value in form of vitamins or other nutrients
- Microbes are used in food production
- Microbes can help control food spoilage

The roles of microorganisms in food Production:

- **Fermentation:** Any desirable change to a food or beverage that occurs as a result of microbial growth
- **Spoilage** is unwanted change to a food due to various reasons
 - Undesirable metabolic reactions
 - Growth of pathogens
 - Presence of unwanted microorganisms in the food
- Use starter cultures in commercial food and beverage production
 - Composed of known microorganisms
 - Consistently perform specific fermentations
- Many common products result from fermentation of vegetables, meats, and dairy products

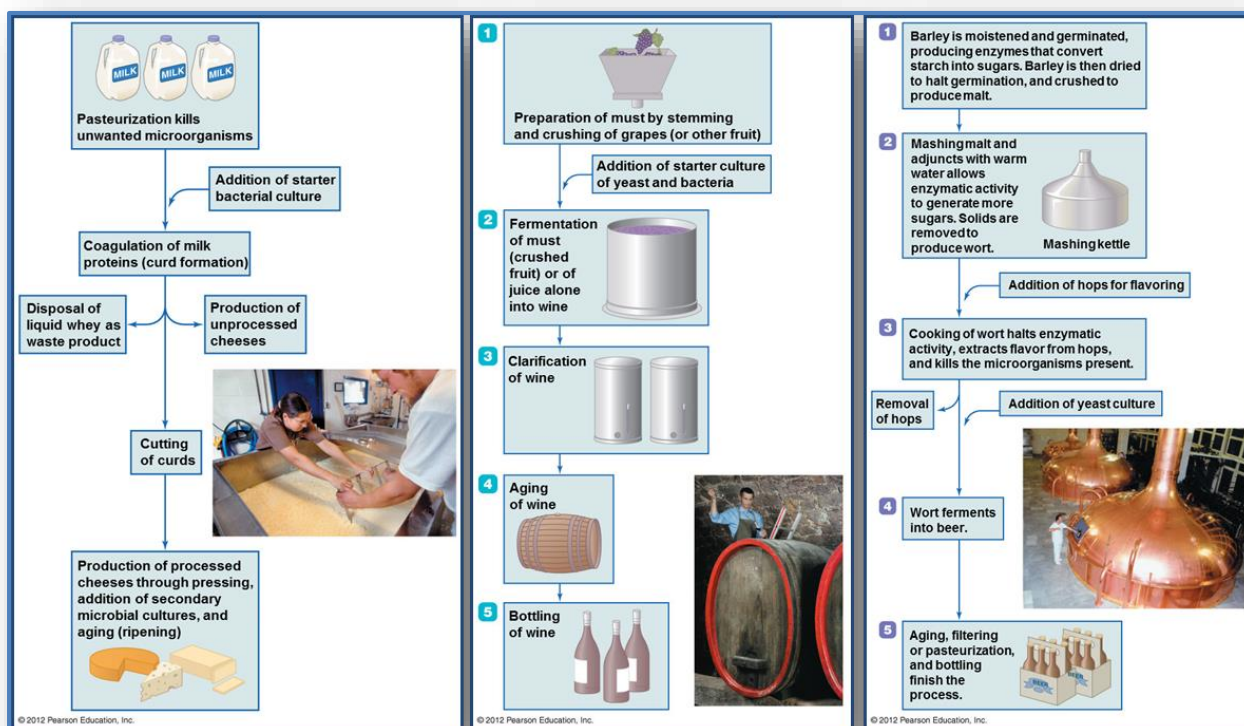

The cheese-making process

The wine-making process

The beer-brewing process

Foodborne Illnesses:

- Consumption of spoiled foods or foods containing harmful microbes or their products
- Two categories of food poisoning
 1. Food infections: Consumption of living microorganisms
 2. Food intoxications: Consumption of microbial toxins rather than the microbe
- Symptoms include nausea, vomiting, diarrhea, fever, fatigue, and muscle cramps

Chapter Ten: Introduction to Industrial Microbiology

- Important field within the microbiological sciences
- Industrial microbiology used in various applications
 - Microbes in fermentation
 - Microbes in the production of several industrial products
 - Treatment of water and wastewaters
 - Disposal and cleanup of biological wastes
 - Treatment of mine drainage

The Roles of Microbes in Industrial Fermentations:

- Industrial fermentations
- Large-scale growth of particular microbes for producing beneficial compounds
- Examples include amino acids and vitamins

1. Primary metabolites

- Produced during active growth and metabolism
- Required for reproduction or are by-products of metabolism

2. Secondary metabolites

- Produced after the culture has entered stationary growth
- Substances are not immediately needed for growth



Fermentation vats

Industrial Products of Microorganisms:

1. Enzymes and other industrial products

Microbial products used as food additives and supplements including vitamins, amino acids, organic acids, dyes

2. Alternative fuels:

- Some microbes produce carbohydrates used as fuels
- Other microbes convert biomass into renewable fuels



3. Pharmaceuticals:

Includes antimicrobials, recombinant hormones, and other cell regulators

4. Pesticides and agricultural products: Microbes used to help crop management

5. Biosensors and bioreporters

- Use of microorganisms to solve environmental problems
- Biosensors: Bacteria or microbial products combined with electronic measuring devices
- Bioreporters: Composed of microbes with innate signaling capabilities

6. Water Treatment

- **Wastewater:** Water that leaves homes or businesses after use
- Wastewater contains a variety of contaminants
- Treatment intended to remove or reduce contaminants
- Processed to reduce the biochemical oxygen demand (BOD)
 - Oxygen needed by aerobic bacteria to metabolize wastes
 - Levels reduced so unable to support microbial growth

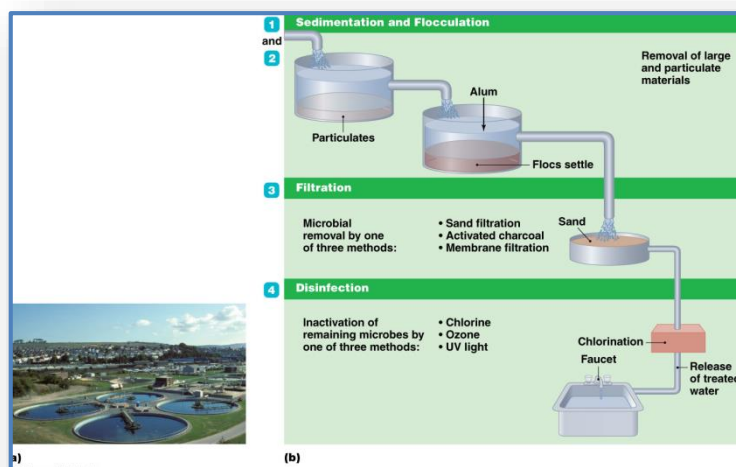

Treatment of drinking water-overview

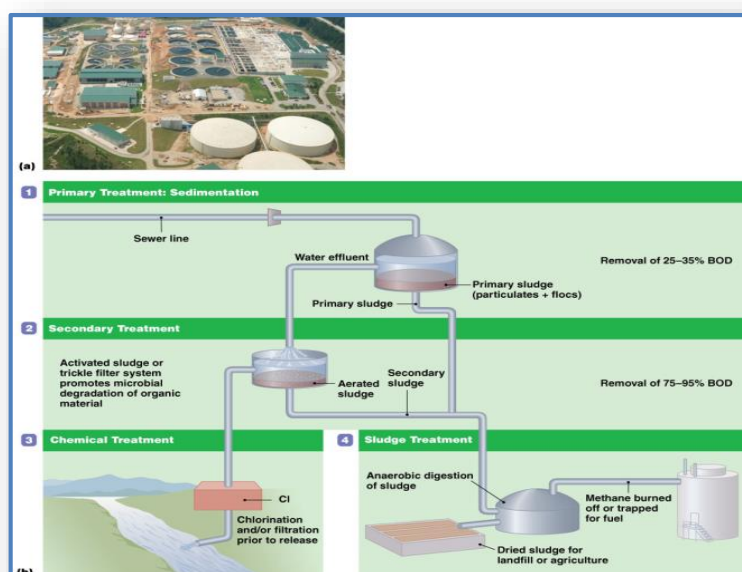

Traditional sewage treatment-overview

Chapter Eleven: Introduction to medical microbiology and Immunity

11.1. Medical microbiology

Human–Microbial Interactions:

- Through normal everyday activities, the human body is exposed to **countless microorganisms** in the environment.
- In addition, hundreds of species and countless individual microbial cells, collectively referred to as the **normal microbial flora**, grow on or in the **human body**.
- **Most**, but not all, microorganisms are **benign**; a few **contribute** directly to our **health**, and even **fewer** pose direct **threats** to **health**.

Colonization by Microorganism:

- Mammals in **utero** develop in a **sterile environment** and have no exposure to microorganisms.
- Starting with the **birth** process, colonization, growth of a microorganism after it has gained access to host tissues, begins as animals are **exposed to microorganisms**
- The **skin surfaces** are readily **colonized** by many species.
- Likewise, the **oral cavity** and **gastrointestinal** tract acquire microorganisms through feeding and exposure to the mother's body, which, along with other environmental sources, initiates colonization of the skin, oral cavity, upper respiratory tract, and gastrointestinal tract.
- Different populations of microorganisms colonize individuals in different localities and at different times.
- Genetic factors also play a role. Thus, the **normal microbial flora** is highly dependent on the **conditions** to which an individual is exposed.

- The normal flora is **highly diverse** in each individual and may differ significantly between individuals, even in a given population

Pathogen:

- A host is an organism that harbors a **parasite**, another organism that lives on or in the host and causes damage.
- Microbial parasites are called **pathogens**.
- The outcome of a host–parasite relationship depends on **pathogenicity, the ability of a parasite to inflict damage on the host**.
- **Pathogenicity** differs considerably among potential **pathogens**, as does the resistance or susceptibility of the host to the pathogen.
- An **opportunistic pathogen** causes disease only in the absence of normal host resistance. Pathogenicity varies markedly for individual pathogens. The quantitative measure of pathogenicity is called virulence.
- Neither the **virulence** of the **pathogen** nor the relative **resistance** of the host is a constant factor.
- The **host–parasite interaction** is a **dynamic** relationship between the two organisms, influenced by changing conditions in the pathogen, the host, and the environment.

Infection and Disease:

- **Infection** refers to any situation in which a microorganism is established and growing in a host, whether or not the host is harmed.
- **Disease** is damage or injury to the host that impairs host function.
- Infection is **not synonymous** with disease because growth of a microorganism on a host does not always cause host damage.
- Thus, species of the normal microbial flora **have infected the host**, but **seldom** cause disease.

- However, the normal flora sometimes cause disease if **host resistance is compromised**, as happens in diseases such as cancer and acquired immune deficiency syndrome (AIDS).

Host–Parasite Interactions

- Animal hosts provide **favorable environments** for the growth of many microorganisms.
- They are rich in the organic nutrients and growth factors required by chemoorganotrophs, and provide conditions of controlled pH, osmotic pressure, and temperature.
- However, the animal body **is not a uniform** environment.
- Each region or **organ** differs **chemically** and **physically** from others and thus provides a selective environment where the growth of certain microorganisms is favored.
- For example, the skin, respiratory tract, and gastrointestinal tract provide selective chemical and physical environments that support the growth of a highly diverse microflora.
- **Animals** also possess **defense mechanisms** that collectively **prevent** or **inhibit** microbial invasion and growth.
- The microorganisms that successfully colonize the host have **circumvented** these **defense** mechanisms.

The Infection Process:

- Infections frequently begin at sites in the animal's **mucous membranes**.
- **Mucous membranes** consist of single or multiple layers of epithelial cells, tightly packed cells that interface with the external environment.
- They are found throughout the body, lining the urogenital, respiratory, and gastrointestinal tracts.
- Mucous membranes are frequently coated with a protective layer of viscous soluble glycoproteins called **mucus**.

- Microorganisms that contact host tissues at mucous membranes may associate loosely with the mucosal surface and are usually **swept away** by physical processes.
- Microorganisms may also adhere more strongly to the epithelial surface as a result of specific cell–cell recognition between pathogen and host.
- Tissue infection may follow, **breaching** the mucosal barrier and allowing the microorganism to **invade deeper** into submucosal tissues.

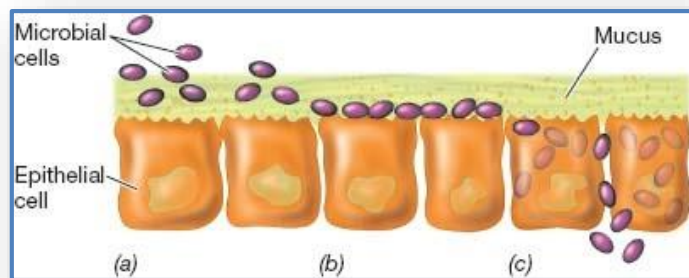

Bacterial interactions with mucous membranes. (a) Loose association. (b) Adhesion. (c) Invasion into submucosal epithelial cells.

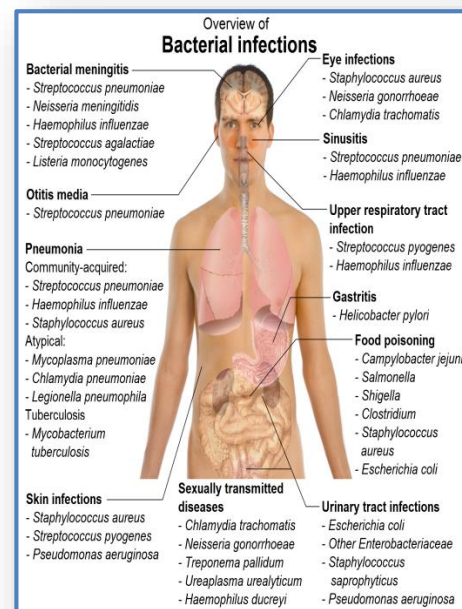
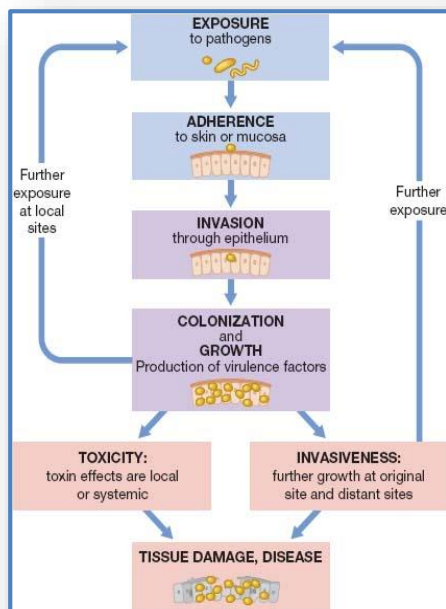

Microorganisms and mechanisms of pathogenesis

11.2. Introduction to immunology

- **Immunity**: is a biological term that describes a state of having sufficient biological defenses to avoid infection, disease, or other unwanted biological invasion.
- Immunity involves both **specific** and **non-specific** components.
- The **non-specific** components act either as **barriers** or as **eliminators** of wide range of pathogens irrespective of antigenic specificity.
- Other components of the immune system **adapt** themselves to **each new disease** encountered and are able to generate pathogen-specific immunity.

1. Innate immunity:

- Innate immunity or nonspecific, immunity is **the natural resistance** with which a person is **born**.
- It provides resistance through several **physical, chemical, and cellular** approaches.
- Microbes first encounter the epithelial layers, physical barriers that line our skin and mucous membranes.
- Subsequent general defenses include **secreted chemical** signals (cytokines), **antimicrobial** substances, fever, and phagocytic activity associated with the inflammatory response.
- The phagocytes express cell surface receptors that can bind and respond to common molecular patterns expressed on the surface of invading microbes. Through these approaches, innate immunity can prevent the colonization, entry, and spread of microbes.

2. Adaptive immunity:

- Adaptive immunity is often sub-divided into two major types depending on how the immunity was introduced:
 - **Naturally acquired** immunity occurs through contact with a disease causing agent, when the contact was **not deliberate**

- **Artificially acquired** immunity develops only through deliberate actions such as **vaccination**.
- Both naturally and artificially acquired immunity can be further subdivided depending on whether immunity is induced in the host or passively transferred from a immune host.
 - **Passive immunity** is acquired through **transfer of antibodies** or activated T-cells from an immune host, and is short lived -- usually lasting only a few months
 - **Active immunity** is induced in the host **itself by antigen**, and lasts much longer, sometimes life-long. The diagram below summarizes these divisions of immunity.

